

Dragite with House Membrane

COR10491

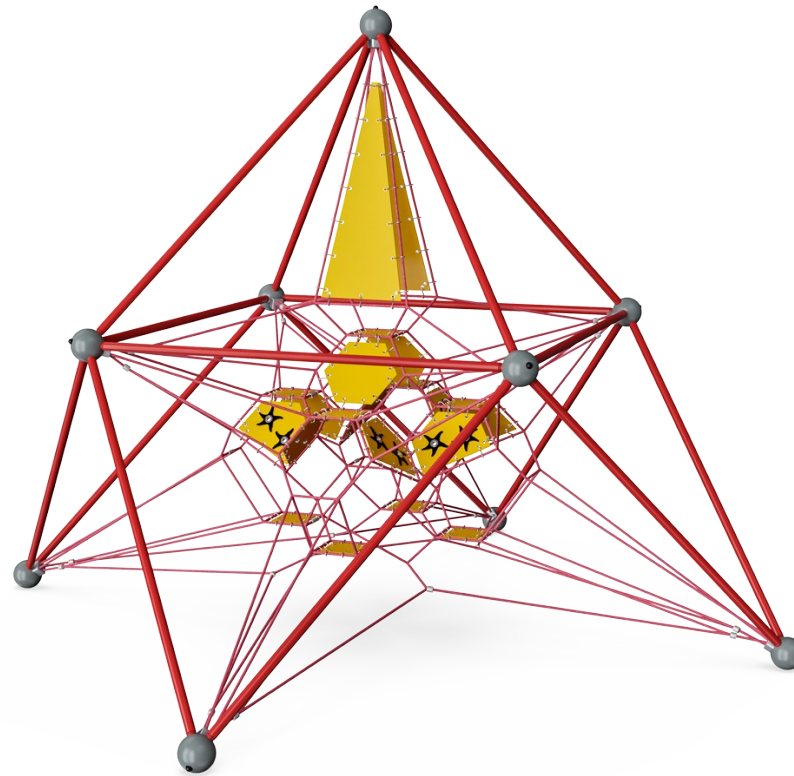

Item no. COR104911-0401	
General Product Information	
Dimensions LxWxH	437x437x436 cm
Age group	3+
Play capacity (users)	28
Colour options	

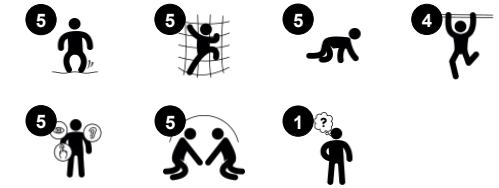

The vibrant colours and responsive, bouncy ropes, nets, and membranes of the Dragite is a popular attraction for children. The varied climbing and meeting options make them want to come back again and again. The lower, yellow membrane squares provide a destination to climb to and with bouncy seats that additionally support climbing onwards. This

provides motion support in climbing for younger or less confident climbers, and variation for all. Additionally, the membranes function as meeting and retraction spots in the climbing landscape. The main attraction is the bouncy climb up, down, and across the Dragite. Concentration is needed when holding tight, as the ropes are inter-connected and reflect the

movements of all climbers throughout the net. This trains muscles, cross-body coordination, and spatial awareness which are important for security in motion.

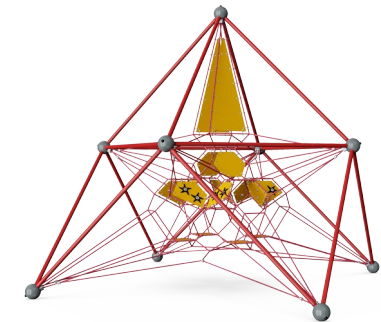

Dragite with House Membrane

COR10491

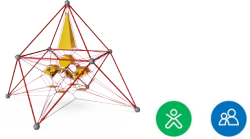

Connected nets

Physical: the connected nets make the climbers feel the movements of the other climbers. All muscle groups are trained, as well as cross coordination. **Social-Emotional:** the climbers' movements affect the other climbers, so consideration and turn-taking is supported.

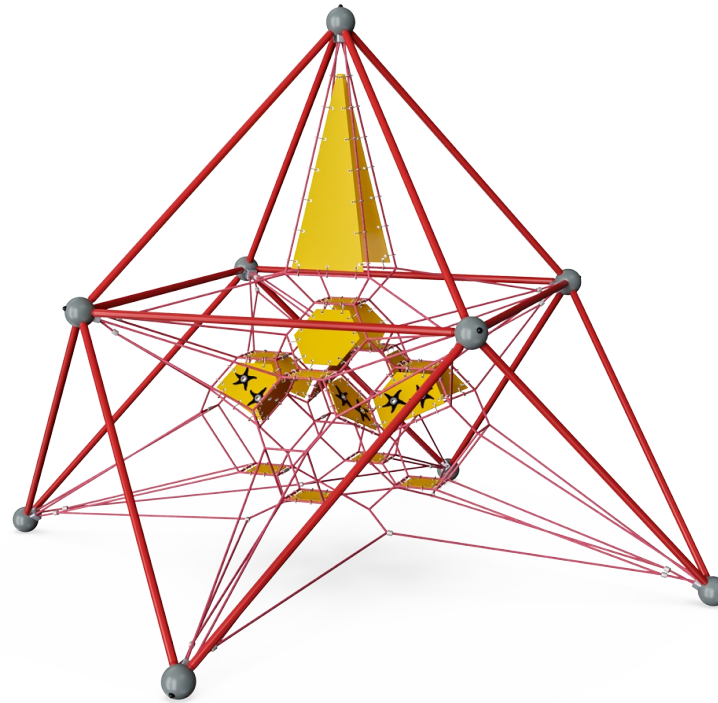

Big meshes

Physical: the big meshes allow for climbing and crawling, supporting proprioception, cross coordination and spatial awareness. **Social-Emotional:** allow more children being seated together, sharing.



Membrane

Physical: the bouncy membrane develops the sense of balance when the child stands, steps or sits here. A faster way up, due to the extra support of the membrane. **Social-Emotional:** a meeting point for retreat from the rope landscape.

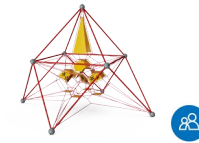

Transparency

Social-Emotional: the transparency makes cooperation and communication possible, which are essential life skills for children to learn.

Dragite with House Membrane

COR10491



Designed to allow the typical function of rope play structures to move Corocord 'S' clamps are used as universal connections in Corocord products. 8mm stainless steel rods with rounded edges are pressed around the ropes with a special hydraulic press, making them the ideal connector. Our clamps are safe, durable and vandalism-proof.



The aluminium swages of the net are double conical with rounded ends and are as small as safety allows. The overall net design aims at keeping metal parts within the net to an absolute minimum, both in size and number, to provide the best possible rope climbing experience.

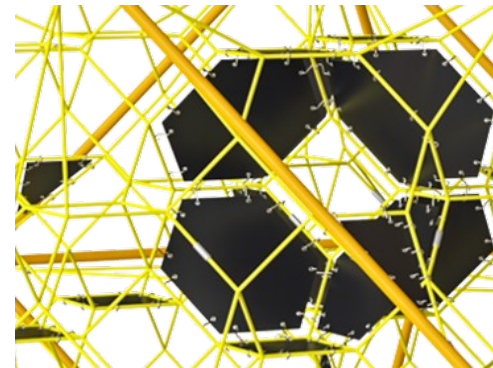

Corocord membranes consist of friction-proof rubberised material of conveyor belt quality with excellent UV resistance. Tested and compliant with REACH requirements for PAH. Embedded is a four-layered armouring made of woven polyester. The armouring and the two surface layers result in a total thickness of 7.5 mm.



The metal parts are made from high-quality steel consisting of hot-dip galvanisation on both the inside and outside and also includes lead-free zinc and an additional layer of powder coating. This ensures both excellent corrosion resistance and colourful design expression.

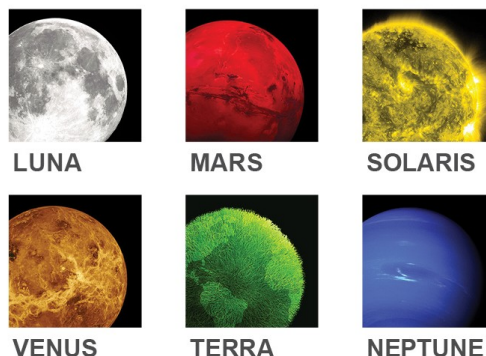

The COROCORD Frame Nets are available in 8 colour themes, ranging from elegant to expressive black or a natural neutral sand colour section to bright eye-catching signal colours which appeals to children of all ages.

Item no. COR104911-0401	
Installation Information	
Max. fall height	230 cm
Safety surfacing area	57.4 m ²
Total installation time	16.5
Excavation volume	1.76 m ³
Concrete volume	0.98 m ³
Footing depth (standard)	110 cm
Shipment weight	616 kg
Anchoring options	In-ground ✓
Warranty Information	
Corocord (Hercules) Rope	10 years
EcoCore HDPE Membrane	Lifetime
Galvanised Steel	Lifetime
Spare Parts Guarantee	10 years



Sustainability Data

COR10491

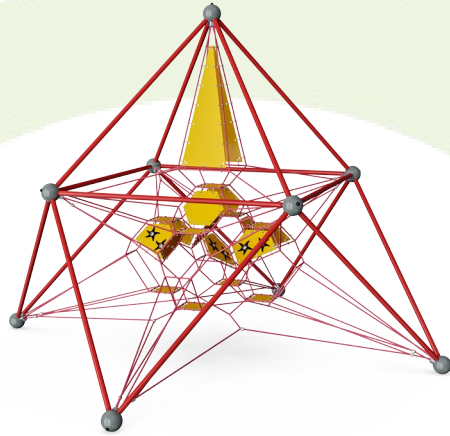

Cradle to Gate A1-A3	Total CO ₂ emission	CO ₂ e/kg	Recycled materials
	kg CO ₂ e	kg CO ₂ e/kg	%
COR104911-0401	1,549.10	3.58	42.19

The overall framework applied for these factors is the Environmental Product Declaration (EPD), which quantifies "environmental information on the life cycle of a product and enable comparisons between products fulfilling the same function" (ISO, 2006). This follows the structure and applies a Life-Cycle Assessment approach to the entire Product stage from raw material through manufacturing (A1-A3))

Kompan A/S
 C.F. Tietgens Boulevard 32C
 DK-5220 Odense SØ
 Denmark



Verification of CO₂ calculation of: Corocord



Data version no. 2023-10-05

The CO₂ calculation and data are in compliance with the principles of a carbon footprint impact according to the GHG protocol (Greenhouse Gas Protocol), Scope 3, cradle to gate related to all individual components in the product category: "Corocord" represented by item no.: COR314011-1101.

(Scope 3 emissions include emission sources in the upstream and downstream value chain).

Date: 30. October 2023 | Valid until: 30. October 2025

Verified by:

Julie Marie Vejsgaard Larsen, LCA & EPD Consultant

Verification based on report: Validation of CO₂ calculation of 9 categories of Kompan product line, version 1.0, prepared by: Bureau Veritas HSE, Denmark: Julie M. V. Larsen.

Publication date: 30. October 2023

By Bureau Veritas HSE
 www.bureauveritas.dk
 +45 7731 1000



Dragite with House Membrane

COR10491

* Max fall height | ** Total height | *** Safety surfacing area

* Max fall height | ** Total height

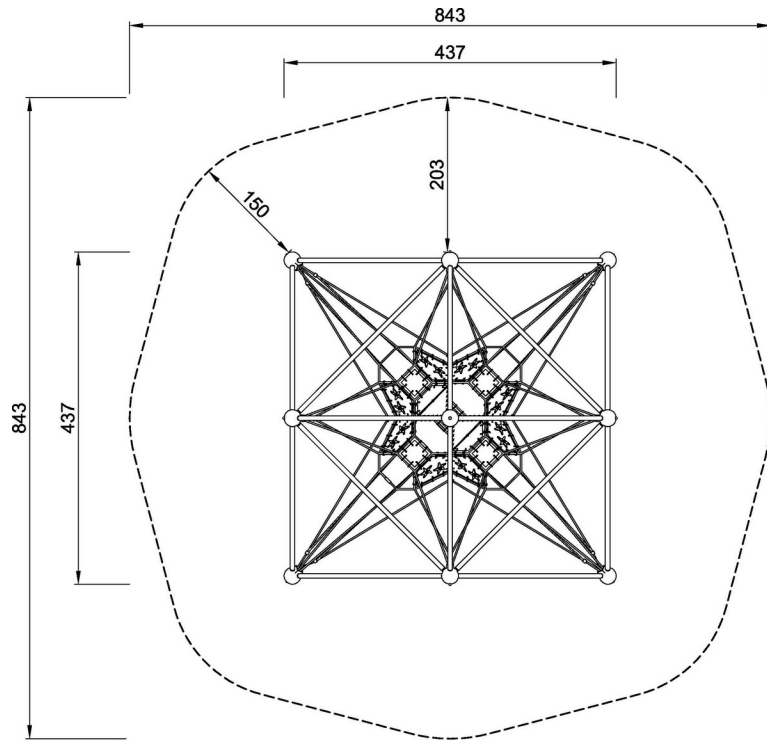

COR104911
*230cm
**436cm
***57.4m²

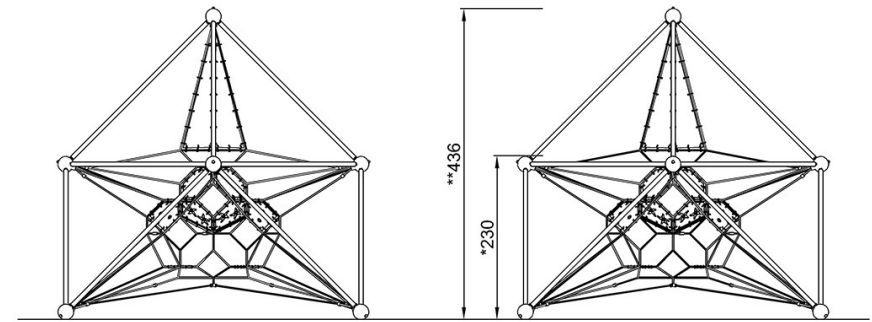

COR104911

[Click to see TOP VIEW](#)

[Click to see SIDE VIEW](#)