

Spinner Bowl

ELE400024



Item no. ELE400024-3717LG	
General Product Information	
Dimensions LxWxH	52x55x60 cm
Age group	4 - 12
Play capacity (users)	1
Colour options	



This wildly or mildly spinning piece with its cute rounded design evokes squeals of joy when children rotate again and again. With its easily accessible, tilted spinning bowl it invites children of all abilities and a wide age span to play. The small footprint allows for placing 2-3 Spinner Bowls together, encouraging social play. The variety of play opportunities: sitting in,

on edge of, pushing, pulling or even standing in the spinner bowl makes for a long-time attraction. The tilted bowl allows the child to adjust the spinning speed with its body movements. This trains the logical thinking: to speed up by scooping up or slow down by spreading arms and legs out. Spinner Bowls train the sense of balance, which is mandatory

for concentration skills and the ability to sit still. Pushing or being pushed by others trains social-emotional skills such as turn-taking.



Spinner Bowl

ELE400024



Tilted, spinning bowl

Physical: the sense of balance and coordination are supported when spinning, effecting the ability to sit still. Muscles are developed when pushing or pulling friends. Can be turned by own body movements or with help. Can be pushed also from a wheelchair position. **Social-Emotional:** cooperation, helping others, turn-taking. **Cognitive:** logical thinking when speeding up or slowing down the spin by either curling up or stretching.



Deep bowl

Social-Emotional: feeling of security when scooping in the bowl. The supportive sides support a wide spectre of mobility impairments due to the height. Inclusive for all abilities.

Spinner Bowl

ELE400024



The Spinner Bowl is made of recyclable PE made from 33% post-consumer materials. The bowl is molded in one piece with integrated metal thread bushings and a water drain hole to ensure high durability in all climates around the world.



Heavy duty engineered bearing system with single row deep groove ball bearings with rubber seals. The fully closed bearing construction is lifetime lubricated and maintenance free.



The steel surfaces are hot dip galvanised inside and outside with lead free zinc. The galvanisation has excellent corrosion resistance in outside environments and requires low maintenance.



The Spinner Bowl is available in six different colour options.



The sand colored variant is made of rotomolded stone mixed PE made from 33% post consumer materials with a non skid surface texture. Minor differences in the stone mix visuality of the material are to be expected.



GreenLine versions in teal color are designed with molded PE parts which consist of 33% recycled post-consumer ocean waste. Ocean waste is collected from the maritime industry, such as fishing nets, ropes and trawls.

Item no. ELE400024-3717LG

Installation Information

Max. fall height	60 cm
Safety surfacing area	13.8 m ²
Total installation time	1.2
Excavation volume	0.11 m ³
Concrete volume	0.06 m ³
Footing depth (standard)	90 cm
Shipment weight	22 kg
Anchoring options	In-ground ✓ Surface ✓

Warranty Information

Bearing construction	5 years
Hardware	10 years
Hollow PE parts	10 years
Hot dip galvanised steel	Lifetime
Spare parts guaranteed	10 years

Elevated activities 0	Accessible elevated activities	Accessible ground level activities	Accessible ground level play types
Present	0	1	1
Required	0	1	1



Sustainability Data

ELE400024



Cradle to Gate A1-A3	Total CO ₂ emission	CO ₂ e/kg	Recycled materials
	kg CO ₂ e	kg CO ₂ e/kg	%
ELE400024-3717LG	55.26	2.99	40.12

The overall framework applied for these factors is the Environmental Product Declaration (EPD), which quantifies "environmental information on the life cycle of a product and enable comparisons between products fulfilling the same function" (ISO, 2006). This follows the structure and applies a Life-Cycle Assessment approach to the entire Product stage from raw material through manufacturing (A1-A3))

Kompan A/S
 C.F. Tietgens Boulevard 32C
 DK-5220 Odense SØ
 Denmark



Verification of CO₂ calculation of: Freestanding play equipment



Data version no. 2023-10-05

The CO₂ calculation and data are in compliance with the principles of a carbon footprint impact according to the GHG protocol (Greenhouse Gas Protocol), Scope 3, cradle to gate related to all individual components in the product category: "Freestanding play equipment" represented by item no.: GXY916012-3417.

(Scope 3 emissions include emission sources in the upstream and downstream value chain).

Date: 30. October 2023 | Valid until: 30. October 2025

Verified by:

Julie Marie Vejsgaard Larsen, LCA & EPD Consultant

Verification based on report: Validation of CO₂ calculation of 9 categories of Kompan product line, version 1.0, prepared by: Bureau Veritas HSE, Denmark: Julie M. V. Larsen.

Publication date: 30. October 2023

By Bureau Veritas HSE
 www.bureauveritas.dk
 +45 7731 1000



Spinner Bowl

ELE400024

* Max fall height | ** Total height | *** Safety surfacing area

* Max fall height | ** Total height

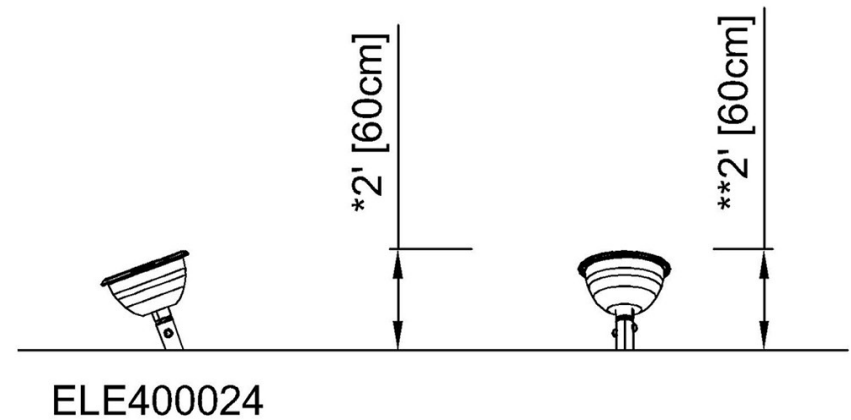
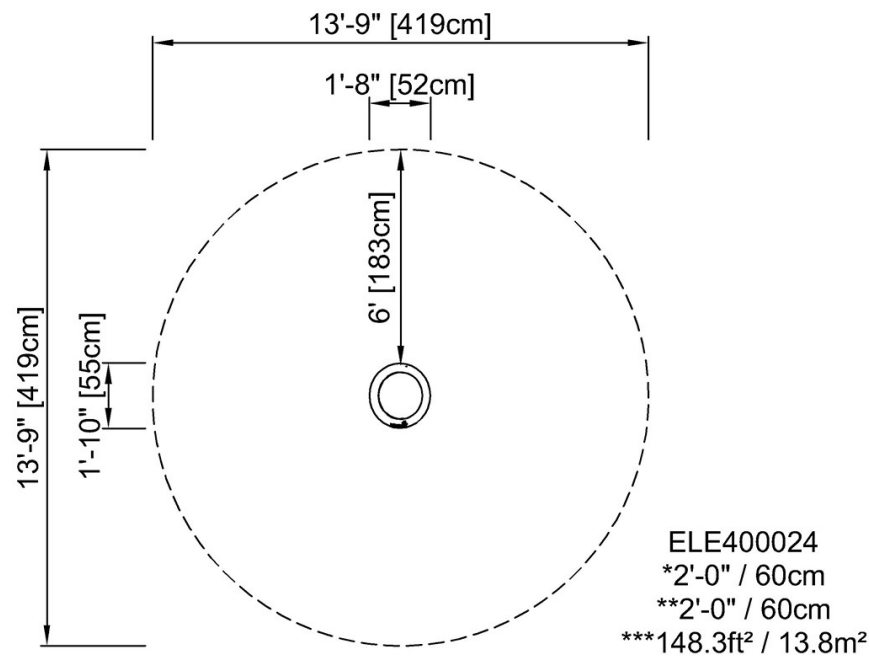

[Click to see TOP VIEW](#)

[Click to see SIDE VIEW](#)