

Cross Trainer Pro Touchscreen

FAZ52101

KOMPAN
Let's play



Item no. FAZ52101-0801	
General Product Information	
Dimensions LxWxH	179x83x175 cm
Age group	13+
Play capacity (users)	1
Color options	



See KOMPAN Fit app for more



The popular cross-trainer known from indoor fitness is now available for outdoor training. With the best ergonomics on the market, KOMPAN's Cross Trainer gives an intense workout and adds an extra intensity layer with a special sprint mode (glute mode) that allows a high-calorie workout that strengthens the gluteus and lower limbs while focusing on the

core stabilizer muscles. The KOMPAN Cross Trainer provides a safe, non-impacting workout without putting unnecessary stress on the joints. The KOMPAN cardio family is designed to give users of all ages, physiques and fitness levels a cardiovascular training that keeps their heart rate above the needed 65% of their maximum heart rate. The intelligent system

automatically adapts the workout to the pace set by the user, securing that the user gets a proper resistance. Besides the automatic drive the user can also choose to manually adjust the resistance, either by using the touch screen or the KOMPAN cardio APP.

Cross Trainer Pro Touchscreen

FAZ52101



You can connect the cardio machine to your phone or tablet via Bluetooth. This will provide instant feedback on speed, distance, cadence, watts, calories burned and time. You can also use your smart devices to manually adjust resistance (10 levels), have access to instructional and motivational videos, store and share activity data online!



The durable 7" LCD, touchscreen with IK8 protection glass gives instant feedback on speed, distance, time, burned calories etc. The resistance of the crosstrainer can be adjusted on the screen.



The cover is made of one of the hardest materials in the market, a Lexan Copolymer EXL9330 and has a thickness of 4mm. This cover can withstand any impact and will protect the electronics in the best possible way.

Item no. FAZ52101-0801	
Installation Information	
Max. fall height	60 cm
Safety surfacing area	15.3 m ²
Total installation time	3.8
Excavation volume	0.68 m ³
Concrete volume	0.42 m ³
Footing depth (standard)	80 cm
Shipment weight	317 kg
Anchoring options	In-ground ✓ Surface ✓



The Innovative self-powered electrical motor and gear providing a virtual flywheel to give real road experience. The resistance works as an automatic drive and adapts automatically. The users can overwrite the automatic drive manually by changing the resistance in 10 steps (45-750 Watts) through the App or screen.



The handle bars are designed with multiple hand positions to accommodate different postures and riding styles. It is a casted Aluminium part with Polyurea coating for good grip and insulation.



The footrests are made 39cm long x 15cm wide, accommodating all foot sizes. The back of the footrest has a specifically designed inclined surface which will bring the users in a sprint position, using much more of the gluteus, hamstrings and lower back muscles.



Sustainability Data

FAZ52101



Cradle to Gate A1-A3	Total CO ₂ emission	CO ₂ e/kg	Recycled materials
	kg CO ₂ e	kg CO ₂ e/kg	%
FAZ52101-0801	596.60	3.11	45.40

The overall framework applied for these factors is the Environmental Product Declaration (EPD), which quantifies "environmental information on the life cycle of a product and enable comparisons between products fulfilling the same function" (ISO, 2006). This follows the structure and applies a Life-Cycle Assessment approach to the entire Product stage from raw material through manufacturing (A1-A3))

Kompan A/S
 C.F. Tietgens Boulevard 32C
 DK-5220 Odense SØ
 Denmark



Verification of CO₂ calculation of: Fitness



Data version no. 2023-10-05

The CO₂ calculation and data are in compliance with the principles of a carbon footprint impact according to the GHG protocol (Greenhouse Gas Protocol), Scope 3, cradle to gate related to all individual components in the product category: "Fitness" represented by item no.: FAZ10100-0900.

(Scope 3 emissions include emission sources in the upstream and downstream value chain).

Date: 30. October 2023 | Valid until: 30. October 2025

Verified by:

Julie Marie Vejsgaard Larsen, LCA & EPD Consultant

Verification based on report: Validation of CO₂ calculation of 9 categories of Kompan product line, version 1.0, prepared by: Bureau Veritas HSE, Denmark: Julie M. V. Larsen.

Publication date: 30. October 2023

By Bureau Veritas HSE
 www.bureauveritas.dk
 +45 7731 1000



Cross Trainer Pro Touchscreen

FAZ52101

* Max fall height | ** Total height | *** Safety surfacing area

* Max fall height | ** Total height

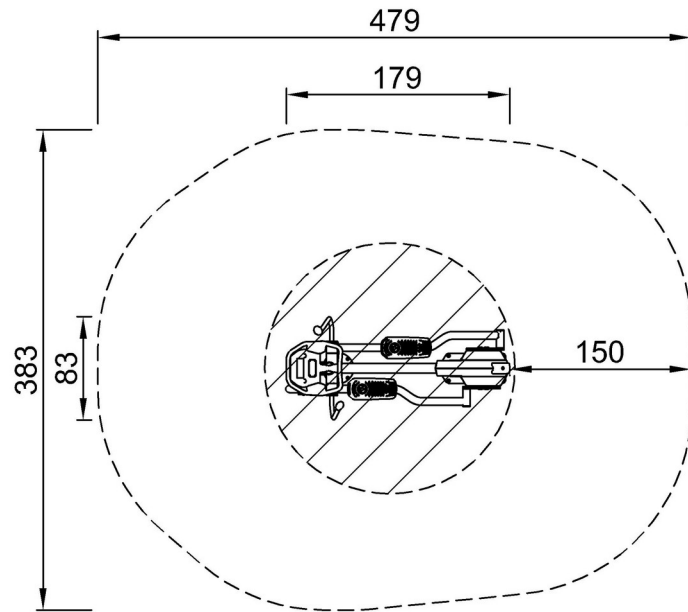

FAZ52101
*60cm
**175cm
***15.3m²

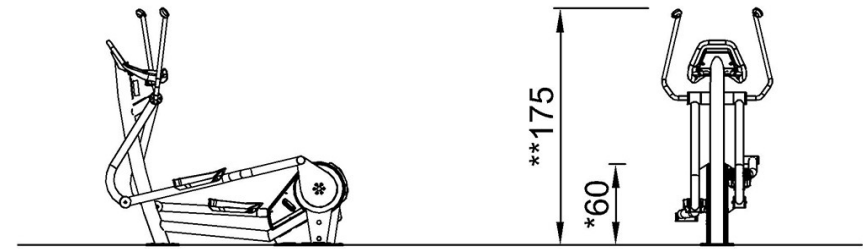

FAZ52101

[Click to see TOP VIEW](#)

[Click to see SIDE VIEW](#)