

# Herenhuis met Café

PCM52321

**KOMPAN**  
Let's play



The countless play activities of the Town House with Cafe inspire children to play, move and imagine together, for long, again and again. The socialise-and explore play features on ground level, with table and bench as well as a wealth of tactile moving play details, offer countless dramatic play scenarios. the play features connect children in play under, around

and on the play unit. The elevated level of the platform gives a good view from above and the high slide is an attractive and stomach tickling experience. Sliding additionally trains the children's spatial awareness, their sense of balance and their core stability. These are important fundamentals in movement confidence. Thus, the Town House with cafe offers

physical, social-emotional and cognitive-creative play benefits in one wildly attractive play unit that children will want to visit again and again.

Item nummer PCM52321-0901

## Algemene Product Informatie

Afmetingen LxBxH	502x290x363 cm
Leeftijdsgroep	2+
Speelcapaciteit	19
Kleuropties	●

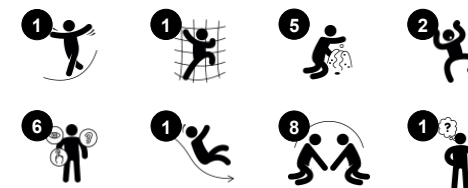

# Herenhuis met Café

PCM52321



Panelen van 19mm EcoCore™. EcoCore™ is een uiterst duurzaam, milieuvriendelijk materiaal. Het is recyclebaar na gebruik en gemaakt van +95% gerecycled post-consumer materiaal van voedselverpakkingsafval.



Main posts with hot dip galvanized steel footing are available in different materials: Pre-galvanized inside and outside with powder coated top finish steel posts. Lead free aluminum with color anodized top finish. TexMade posts of 95% post-consumer recycled PE and textile waste.



Alle platformen worden ondersteund door speciale, koolstofarme profielen met meerdere bevestigingsopties. De grijsgekleurde, gegoten PP platformen zijn gemaakt van 75% post-consumer materiaal en zijn voorzien van een antisliptextuur.

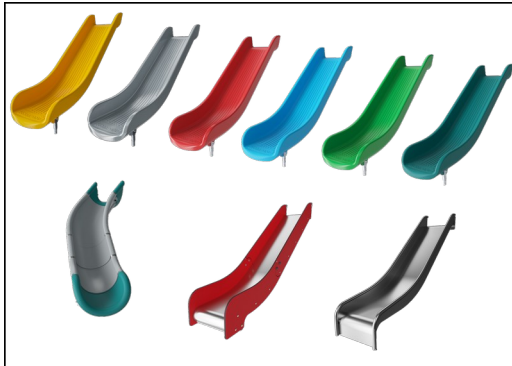

De glijbanen zijn beschikbaar in zes verschillende kleuren en drie materiaalsoorten: Rechte of gebogen PE glijbanen, uit één stuk gegoten, gemaakt van 33% gerecycled post-consumer materiaal. Gecombineerd, met EcoCore™ zijwanden en RVS. Of volledig in RVS en uit één stuk, voor vandalismebestendiger oplossingen.



KOMPAN GreenLine uitvoeringen zijn gemaakt van uiterst milieuvriendelijke materialen met de laagst mogelijke CO2e emissiefactor. TexMade staanders, EcoCore™ panelen van 95% post-consumer gerecycled afval en gegoten PP platformen.

Item nummer PCM52321-0901

## Installatie informatie

Max. valhoogte	148 cm
Veiligheidszone	33,7 m <sup>2</sup>
Totale installatietijd	23,2
Graafwerk (vol.)	0,40 m <sup>3</sup>
Benodigd beton	0,00 m <sup>3</sup>
Verankeringsdiepte	90 cm
Verzendingsgewicht	820 kg
Verankeringsopties	Oppervlak ✓ In-ground ✓

## Garantie informatie

EcoCore HDPE	Levenslang
Holle PE-onderdelen	10 jaar
Staander	10 jaar
PP Decks	10 jaar
Gegarandeerde reserveonderdelen	10 jaar

# Sustainability Data

PCM52321



Cradle to Gate A1-A3	Total CO <sub>2</sub> emission	CO <sub>2</sub> e/kg	Recycled materials
	kg CO <sub>2</sub> e	kg CO <sub>2</sub> e/kg	%
<b>PCM52321-0901</b>	866,08	1,50	74,37

The overall framework applied for these factors is the Environmental Product Declaration (EPD), which quantifies "environmental information on the life cycle of a product and enable comparisons between products fulfilling the same function" (ISO, 2006). This follows the structure and applies a Life-Cycle Assessment approach to the entire Product stage from raw material through manufacturing (A1-A3))

**Kompan A/S**  
 C.F. Tietgens Boulevard 32C  
 DK-5220 Odense SØ  
 Denmark



## Verification of CO<sub>2</sub> calculation of: Play systems



Data version no. 2023-10-05

The CO<sub>2</sub> calculation and data are in compliance with the principles of a carbon footprint impact according to the GHG protocol (Greenhouse Gas Protocol), Scope 3, cradle to gate related to all individual components in the product category: "Play systems" represented by item no.: PCM200321-0950.

(Scope 3 emissions include emission sources in the upstream and downstream value chain).

**Date: 30. October 2023 | Valid until: 30. October 2025**

Verified by:

Julie Marie Vejsgaard Larsen, LCA & EPD Consultant

Verification based on report: Validation of CO<sub>2</sub> calculation of 9 categories of Kompan product line, version 1.0, prepared by: Bureau Veritas HSE, Denmark: Julie M. V. Larsen.

**Publication date: 30. October 2023**

By Bureau Veritas HSE  
 www.bureauveritas.dk  
 +45 7731 1000



# Herenhuis met Café

PCM52321

Max. valhoogte | Totale Hoogte | Veiligheidszone

Max. valhoogte | Totale Hoogte

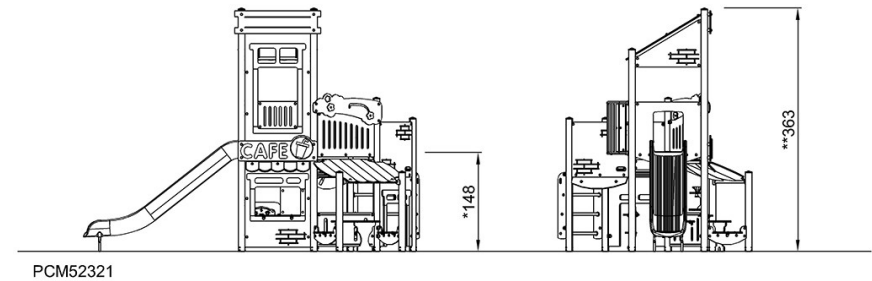
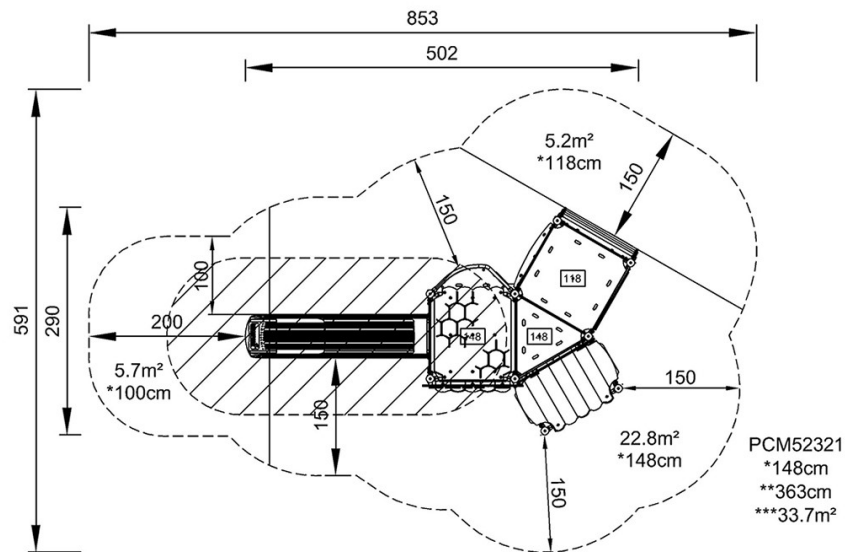

[Bekijk BOVENAANZICHT](#)

[Bekijk ZIJAANZICHT](#)