

Fish Cutter & Shop

PCM52531



Item no. PCM52531-0901	
General Product Information	
Dimensions LxWxH	342x352x311 cm
Age group	2+
Play capacity (users)	13
Color options	



The countless play activities of the Cutter and Fish Shop play unit inspire children to play and imagine together, for long, again and again. The many explorative play features such as play panels with sounding gearing wheels, climb-through dense and the funnel leading to the treasure box all inspire countless dramatic play scenarios while stimulating them to

explore the many tactile, moving play features. The explorative and creative play from the wheels play panel intrigues children's creativity and builds their understanding of cause and effect. Often they spur make-believe play such as shop or cutter. This makes children play together, learn turn-taking and empathy and make friends.



Fish Cutter & Shop

PCM52531



Bucket and pipe

Social-Emotional: invites cooperation due to the two-sidedness. **Cognitive:** the passing of materials through funnels supports the children's logical thinking and for younger children the understanding of object permanence: that materials don't vanish but run through at the other end. **Creative:** children can leave their mark, placing the membranes in different positions.



Theme

Cognitive: suggests a theme and supports dramatic play, which stimulates language and communication skills.



Rope with rubber disc

Physical: children develop cross-body coordination and muscle strength when stepping onto the disc and climbing the rope. Their sense of balance is trained when swaying gently. The sense of balance is important for instance for being able to sit still. **Social-Emotional:** socializing and turn-taking when deciding who should sit here.



Crawl-through hole with curtains

Physical: the hole allows for climbing and crawling through, developing cross coordination, proprioception and spatial awareness. **Social-Emotional:** cooperation and turn-taking when playing with friends on the other side. **Cognitive:** understanding of object permanence: things can disappear without being gone forever – a thrilling insight.



Sound Panel

Physical: turning the wheels require big hand and arm movements. This develops dexterity, hand and arm muscles. **Social-Emotional:** individual and social play: cooperation and co-creation when making specific sounds. **Cognitive:** cause and effect understanding as well as make-believe play. Creating sounds and rhythms trains essential pre-reading skills. **Creative:** creating varied sounds and rhythms.



Gear wheels

Social-Emotional: cooperation skills and turn-taking are supported when turning the gearing wheel. **Cognitive:** cause and effect understanding, and logical thinking are supported.



Steering wheel

Cognitive: the manipulative steering wheel invites dramatic play which supports language and communication skills.

Fish Cutter & Shop

PCM52531



Panels of 19mm EcoCore™. EcoCore™ is a highly durable, eco friendly material, which is not only recyclable after use, but also consists of material produced from +95% recycled post consumer material from food packing waste.



Main posts with hot dip galvanized steel footing are available in different materials: Pre-galvanized inside and outside with powder coated top finish steel posts. Lead free aluminum with color anodized top finish. TexMade posts of 95% post-consumer recycled PE and textile waste.



The steel surfaces are hot dip galvanized inside and outside with lead free zinc. The galvanisation has excellent corrosion resistance in outside environments and requires low maintenance.



KOMPAN GreenLine versions are designed with ultimate environmentally friendly materials with lowest possible CO2e emission factor. TexMade post, EcoCore™ panels of 95% post-consumer recycled waste and molded PP decks.

Item no. PCM52531-0901

Installation Information

Max. fall height	40 cm
Safety surfacing area	28.4 m ²
Total installation time	23.8
Excavation volume	0.43 m ³
Concrete volume	0.00 m ³
Footing depth (standard)	90 cm
Shipment weight	733 kg
Anchoring options	Surface ✓ In-ground ✓

Warranty Information

EcoCore HDPE	Lifetime
Hot dip galvanised steel	Lifetime
Movable parts	2 years
Post	10 years
Spare parts guaranteed	10 years

Sustainability Data

PCM52531



Cradle to Gate A1-A3	Total CO ₂ emission	CO ₂ e/kg	Recycled materials
	kg CO ₂ e	kg CO ₂ e/kg	%
PCM52531-0901	694.10	1.37	78.85

The overall framework applied for these factors is the Environmental Product Declaration (EPD), which quantifies "environmental information on the life cycle of a product and enable comparisons between products fulfilling the same function" (ISO, 2006). This follows the structure and applies a Life-Cycle Assessment approach to the entire Product stage from raw material through manufacturing (A1-A3))

Kompan A/S
 C.F. Tietgens Boulevard 32C
 DK-5220 Odense SØ
 Denmark



Verification of CO₂ calculation of: Play systems



Data version no. 2023-10-05

The CO₂ calculation and data are in compliance with the principles of a carbon footprint impact according to the GHG protocol (Greenhouse Gas Protocol), Scope 3, cradle to gate related to all individual components in the product category: "Play systems" represented by item no.: PCM200321-0950.

(Scope 3 emissions include emission sources in the upstream and downstream value chain).

Date: 30. October 2023 | Valid until: 30. October 2025

Verified by:

Julie Marie Vejsgaard Larsen, LCA & EPD Consultant

Verification based on report: Validation of CO₂ calculation of 9 categories of Kompan product line, version 1.0, prepared by: Bureau Veritas HSE, Denmark: Julie M. V. Larsen.

Publication date: 30. October 2023

By Bureau Veritas HSE
 www.bureauveritas.dk
 +45 7731 1000



Fish Cutter & Shop

PCM52531

* Max fall height | ** Total height | *** Safety surfacing area

* Max fall height | ** Total height

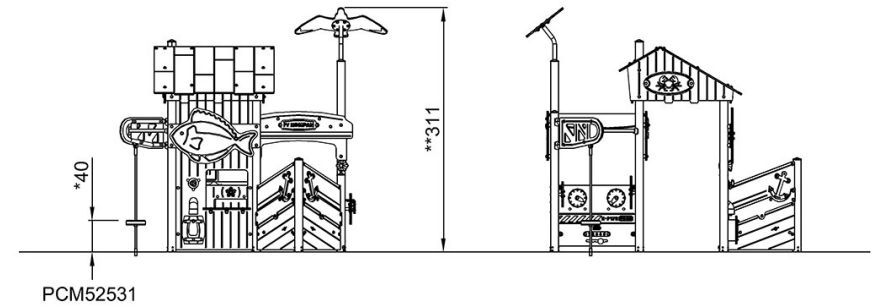
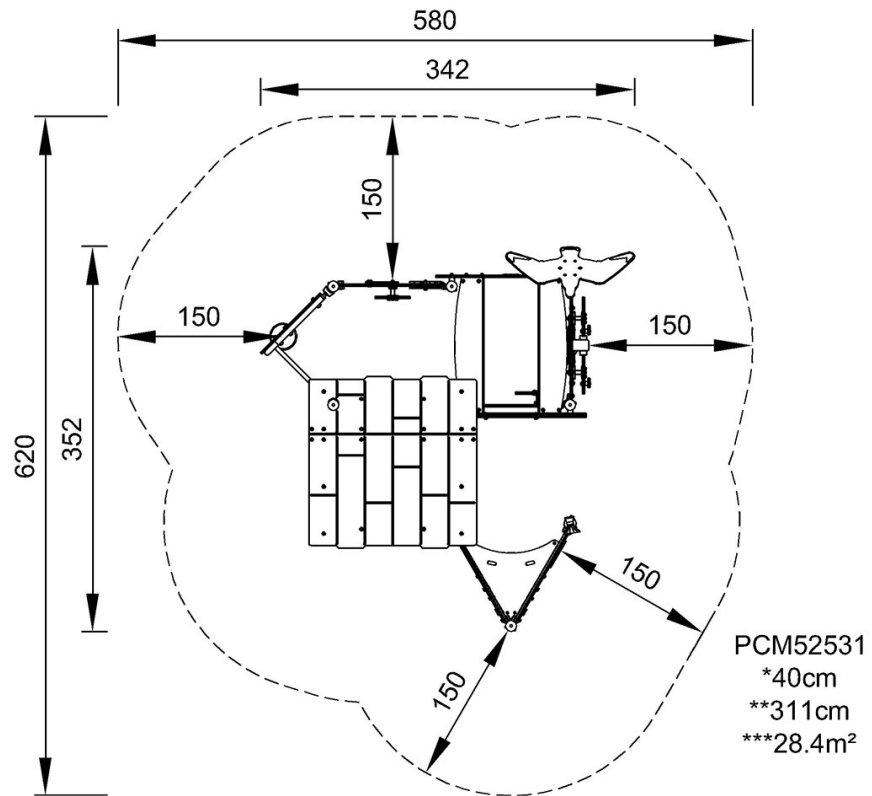

[Click to see TOP VIEW](#)

[Click to see SIDE VIEW](#)