

Balance Board

FSW231



The reactive balance board resembles situations where the contact with the surface suddenly gets unstable. The Balance board mimics situations that occur in metros, buses or on slippery surfaces. It can be used on one or two feet with or without support, but for even more challenging exercises the signs on the high posts can be used. By alternatingly

touching the different symbols in a pre-defined pattern with right and left hand both full body balance, coordination and cognition can be challenged.

Item no. FSW23100-0902

General Product Information

Dimensions LxWxH 87x89x200 cm

Age group 13+

Play capacity (users) 1

Colour options 



See KOMPAN Fit app for more



Balance Board

FSW231



The HPL board is 586mm x 586mm and can move 70mm in all directions. High-pressure laminate plates (HPL) have a moulded-in non-skid surface. HPL is a homogenous material with a very high wear resistance.



The connectors are made of die-cast aluminium, specially alloyed for the outdoor environments and heavy usage. The screws attaching the connectors are stainless steel and protected by zinc washers.



Post are made of Ø101.6 x 2mm, pre-galvanized carbon steel and powder coated, a great protection to all conditions.

Item no. FSW23100-0902

Installation Information

Max. fall height	12 cm
Safety surfacing area	12.8 m ²
Total installation time	4.8
Excavation volume	0.21 m ³
Concrete volume	0.11 m ³
Footing depth (standard)	90 cm
Shipment weight	131 kg
Anchoring options	In-ground ✓ Surface ✓

Warranty Information

Bearing construction	5 years
EcoCore HDPE	Lifetime
Post	10 years
Spare parts guaranteed	10 years
Stainless steel components	Lifetime



The information sign is made of a PA6 (Polyamide) and shows the most relevant exercise and a QR code. When scanned the QR code will link to an animated illustration of the exercise and offers the possibility of downloading the KOMPAN sport & fitness App, which will provide a large amount of exercises and workouts.



All KOMPAN fitness products are compliant with the ASTM F3101 & EN16630 Outdoor Fitness Standards. Load tests are performed as a static test by adding dynamic factors as well as safety factors to the specified load of 78kg per user. A product intended for 1 user is loaded with 420kg.



The balance board is connected to the posts with 506mm long stainless steel (AISI304) chains with 6mm links. The Swivels used are made of PUR coated sintered stainless steel with bronze bearings, providing a strong and smooth movement.



Sustainability Data

FSW231



Cradle to Gate A1-A3	Total CO ₂ emission	CO ₂ e/kg	Recycled materials
	kg CO ₂ e	kg CO ₂ e/kg	%
FSW23100-0902	280.04	3.38	43.40

The overall framework applied for these factors is the Environmental Product Declaration (EPD), which quantifies "environmental information on the life cycle of a product and enable comparisons between products fulfilling the same function" (ISO, 2006). This follows the structure and applies a Life-Cycle Assessment approach to the entire Product stage from raw material through manufacturing (A1-A3))

Kompan A/S
C.F. Tietgens Boulevard 32C
DK-5220 Odense SØ
Denmark



Verification of CO₂ calculation of: Fitness



Data version no. 2023-10-05

The CO₂ calculation and data are in compliance with the principles of a carbon footprint impact according to the GHG protocol (Greenhouse Gas Protocol), Scope 3, cradle to gate related to all individual components in the product category: "Fitness" represented by item no.: FAZ10100-0900.

(Scope 3 emissions include emission sources in the upstream and downstream value chain).

Date: 30. October 2023 | Valid until: 30. October 2025

Verified by:

Julie Marie Vejsgaard Larsen, LCA & EPD Consultant

Verification based on report: Validation of CO₂ calculation of 9 categories of Kompan product line, version 1.0, prepared by: Bureau Veritas HSE, Denmark: Julie M. V. Larsen.

Publication date: 30. October 2023

By Bureau Veritas HSE
www.bureauveritas.dk
+45 7731 1000



Balance Board

FSW231

* Max fall height | ** Total height | *** Safety surfacing area

* Max fall height | ** Total height

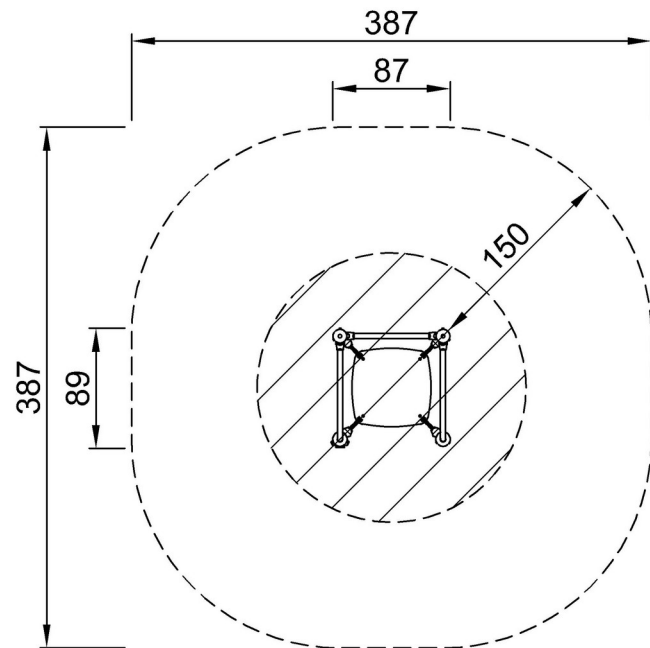

FSW23100
*12cm
**200cm
***12.8m²

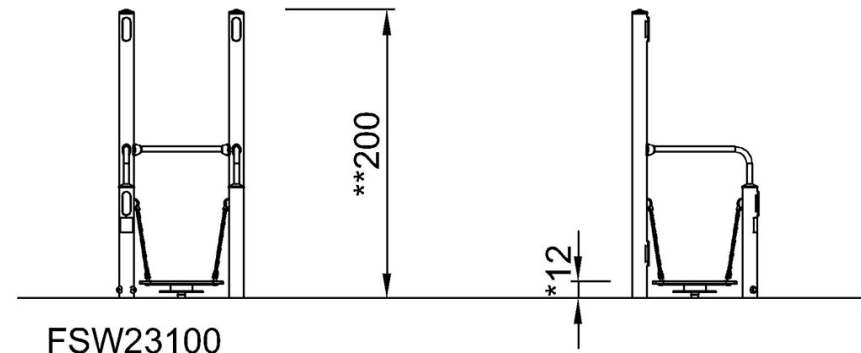

[Click to see TOP VIEW](#)

[Click to see SIDE VIEW](#)