

# Forest Ant Springer

NRO119



The Forest Ant with its shiny antennae and friendly face invites toddlers for shorter or longer rides, over and over again. Apart from its appealing shape, the Forest Ant offers tactile variation with its steel hand hold, rubber foot support and smooth, wooden body. Tactile richness is a main motivator, especially in younger children. It supports their

understanding of material characteristics such as weight, smoothness, temperature and flexibility an important skill in learning risk management. The spring ensures hours, years and decades of fun. The soothing, rocking movement of the Forest Ant trains the sense of balance and spatial awareness, both crucial for body confidence and avoiding falling. A good

sense of balance is essential for the ability to sit still and concentrate.

Item no. NRO119-0421	
<b>General Product Information</b>	
Dimensions LxWxH	2'6"x1'7"x2'5"
Age group	2 - 12
Play capacity (users)	1
Color options	



# Forest Ant Springer

NRO119



## Handhold

**Physical:** the vertical handgrips ensure a firm grip at different heights, necessary for rocking intensely. This trains hand and arm muscles.



## Rocking spring

**Physical:** response to movement increases spatial awareness and sense of balance. These are fundamental motor skills that help the child's ability to sit still on a chair which takes a good sense of balance. **Cognitive:** trains the understanding of cause and effect: when I move my body, the spring responds with movement.



## Foot support

**Physical:** the possibility of footrest supports intense rocking. Rocking stimulates the senses of balance and space that are fundamental in managing the world securely.



## Double seating option

**Social-Emotional:** the possibility of rocking together supports cooperation skills. Furthermore, the physical contact with others is great for the well-being of children, measurable in lower cortisol (stress hormone) levels.



## Theme

**Cognitive:** suggests a theme and supports dramatic play, which stimulates language and communication skills.

# Forest Ant Springer

NRO119



All Organic oak products by KOMPAN are made of oak wood from sustainable European sources. On request it can be supplied as FSC® Certified (FSC® C004450).



The paint used for coloured components is water based environmentally friendly with excellent UV resistance. The paint is in compliance with EN 71 Part 3.



Handles and footrests are made of high-quality stainless steel and equipped with molded on PUR handholds and footsteps. The PUR footrests are designed with grooves to make the surface slip resistant.

Item no. NRO119-0421	
Installation Information	
Max. fall height	1'10"
Safety surfacing area	165ft <sup>2</sup>
Total installation time	1.9
Excavation volume	0.22yd <sup>3</sup>
Concrete volume	0yd <sup>3</sup>
Footing depth (standard)	1'5"
Shipment weight	86lbs
Anchoring options	In-ground ✓ Surface ✓
Warranty Information	
Oak Wood	10 Years
PUR components	10 Years
Spare Parts Availability	10 Years
Springs	5 Years
Stainless steel components	Lifetime



KOMPAN Springs are made of high quality spring steel according to EN10270. The springs are cleaned by phosphating before they are painted with an epoxy primer and a polyester powder coating as top finish. The springs are fixed by unique anti pinch fittings for maximum safety and long lifetime.



Robinia products are available in three different wood treatment options: Untreated Robinia wood or brown painted with a pigment that maintains the wood color and colored version with paint of selected components.

Elevated activities	Accessible elevated activities	Accessible ground level activities	Accessible ground level play types
Present	0	1	1
Required	0	1	1



# Sustainability Data

NRO119



Cradle to Gate A1-A3	Total CO <sub>2</sub> emission	CO <sub>2</sub> e/kg	Recycled materials
	kg CO <sub>2</sub> e	kg CO <sub>2</sub> e/kg	%
NRO119-0421	83.80	2.22	30.90

The overall framework applied for these factors is the Environmental Product Declaration (EPD), which quantifies "environmental information on the life cycle of a product and enable comparisons between products fulfilling the same function" (ISO, 2006). This follows the structure and applies a Life-Cycle Assessment approach to the entire Product stage from raw material through manufacturing (A1-A3))

**Kompan A/S**  
 C.F. Tietgens Boulevard 32C  
 DK-5220 Odense SØ  
 Denmark



## Verification of CO<sub>2</sub> calculation of: Nature play



Data version no. 2023-10-05

The CO<sub>2</sub> calculation and data are in compliance with the principles of a carbon footprint impact according to the GHG protocol (Greenhouse Gas Protocol), Scope 3, cradle to gate related to all individual components in the product category: "Nature play" represented by item no.: NRO409-0621.

(Scope 3 emissions include emission sources in the upstream and downstream value chain).

**Date: 30. October 2023 | Valid until: 30. October 2025**

**Verified by:**

Julie Marie Vejsgaard Larsen, LCA & EPD Consultant

Verification based on report: Validation of CO<sub>2</sub> calculation of 9 categories of Kompan product line, version 1.0, prepared by: Bureau Veritas HSE, Denmark: Julie M. V. Larsen.

**Publication date: 30. October 2023**

**By Bureau Veritas HSE**  
 www.bureauveritas.dk  
 +45 7731 1000



# Forest Ant Springer

NRO119

\* Max fall height | \*\* Total height | \*\*\* Safety surfacing area

\* Max fall height | \*\* Total height

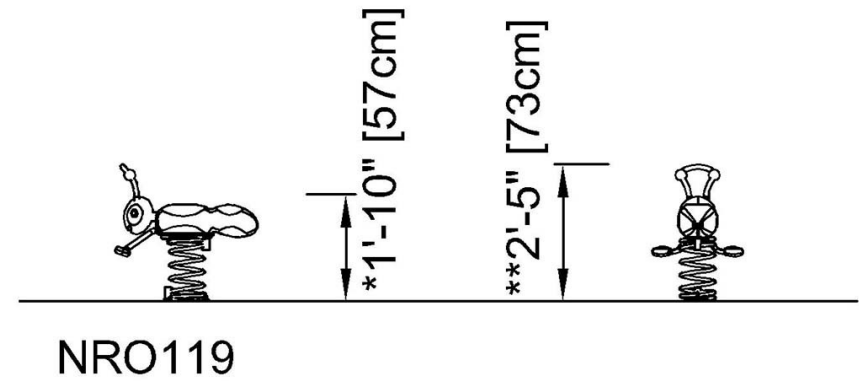
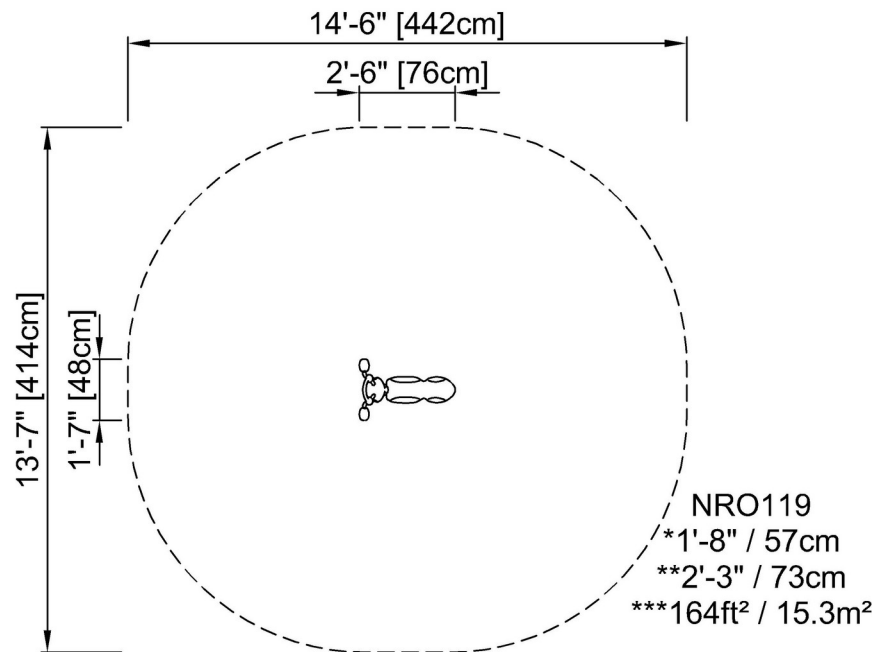

[Click to see TOP VIEW](#)

[Click to see SIDE VIEW](#)