

# Snail Springer

NRO115



Item no. NRO115-0401

## General Product Information

Dimensions LxWxH	73x48x68 cm
Age group	2 - 12
Play capacity (users)	1
Colour options	 



The Snail with its chunky, rocking body attracts toddlers for shorter or longer rides, again and again. Apart from its appealing shape, the Snail offers tactile variation with its steel hand hold, rubber foot support and smooth, wooden body. Tactile richness is a main motivator, especially in younger children. It supports their understanding of material characteristics such

as weight, smoothness, temperature and flexibility. This is important for instance risk management. The spring ensures hours, years and decades of fun. The soothing, rocking movement of the Snail trains the sense of balance and the spatial awareness. These are crucial for body confidence, e.g. in avoiding falling. A good sense of balance is essential for

the ability to sit still and concentrate. So this is much more than a mere fun ride.



# Snail Springer

NRO115



## Handhold

**Physical:** the vertical handgrips ensure a firm grip at different heights, necessary for rocking intensely. This trains hand and arm muscles.



## Rocking spring

**Physical:** response to movements adds to spatial awareness and sense of balance. These are fundamental motor skills that help the child's ability to sit still on a chair which takes a good sense of balance. **Cognitive:** trains the understanding of cause and effect: when I move my body, the spring responds with movement.



## Foot support

**Physical:** the possibility of footrest supports intensive rocking. Rocking stimulates the senses of balance and space that are fundamental in managing the world securely.



## Theme

**Cognitive:** suggests a theme and supports dramatic play, which stimulates language and communication skills.

# Snail Springer

NRO115



All Organic Robinia products by KOMPAN are made of Robinia wood from sustainable European sources. On request it can be supplied as FSC® Certified (FSC® C004450).



The paint used for coloured components is water based environmentally friendly with excellent UV resistance. The paint is in compliance with EN 71 Part 3.



Handles and footrests are made of high-quality stainless steel and equipped with moulded on PUR handholds and footsteps. The PUR footrests are designed with groves to make the surface slip resistant.



KOMPAN Springs are made of high quality spring steel according to EN10270. The springs are cleaned by phosphating before they are painted with an epoxy primer and a polyester powder coating as top finish. The springs are fixed by unique anti pinch fittings for maximum safety and long lifetime.



The Robinia wood can be supplied as untreated raw wood or painted with a brown coloured transparent pigment that maintains the golden wood colour of the wood.

Item no. NRO115-0401	
Installation Information	
Max. fall height	51 cm
Safety surfacing area	15.5 m <sup>2</sup>
Total installation time	2.2
Excavation volume	0.17 m <sup>3</sup>
Concrete volume	0.00 m <sup>3</sup>
Footing depth (standard)	42 cm
Shipment weight	59 kg
Anchoring options	In-ground ✓ Surface ✓
Warranty Information	
PUR components	10 years
Robinia wood	15 years
Spare parts guaranteed	10 years
Springs	5 years
Stainless steel components	Lifetime

Elevated activities 0	Accessible elevated activities	Accessible ground level activities	Accessible ground level play types
Present	0	1	1
Required	0	1	1



# Sustainability Data

NRO115



Cradle to Gate A1-A3	Total CO <sub>2</sub> emission	CO <sub>2</sub> e/kg	Recycled materials
	kg CO <sub>2</sub> e	kg CO <sub>2</sub> e/kg	%
<b>NRO115-0401</b>	82.03	1.49	32.39

The overall framework applied for these factors is the Environmental Product Declaration (EPD), which quantifies "environmental information on the life cycle of a product and enable comparisons between products fulfilling the same function" (ISO, 2006). This follows the structure and applies a Life-Cycle Assessment approach to the entire Product stage from raw material through manufacturing (A1-A3))

**Kompan A/S**  
 C.F. Tietgens Boulevard 32C  
 DK-5220 Odense SØ  
 Denmark



## Verification of CO<sub>2</sub> calculation of: Nature play



Data version no. 2023-10-05

The CO<sub>2</sub> calculation and data are in compliance with the principles of a carbon footprint impact according to the GHG protocol (Greenhouse Gas Protocol), Scope 3, cradle to gate related to all individual components in the product category: "Nature play" represented by item no.: NRO409-0621.

(Scope 3 emissions include emission sources in the upstream and downstream value chain).

**Date: 30. October 2023 | Valid until: 30. October 2025**

**Verified by:**

Julie Marie Vejsgaard Larsen, LCA & EPD Consultant

Verification based on report: Validation of CO<sub>2</sub> calculation of 9 categories of Kompan product line, version 1.0, prepared by: Bureau Veritas HSE, Denmark: Julie M. V. Larsen.

**Publication date: 30. October 2023**

**By Bureau Veritas HSE**  
 www.bureauveritas.dk  
 +45 7731 1000



# Snail Springer

NRO115

\* Max fall height | \*\* Total height | \*\*\* Safety surfacing area

\* Max fall height | \*\* Total height

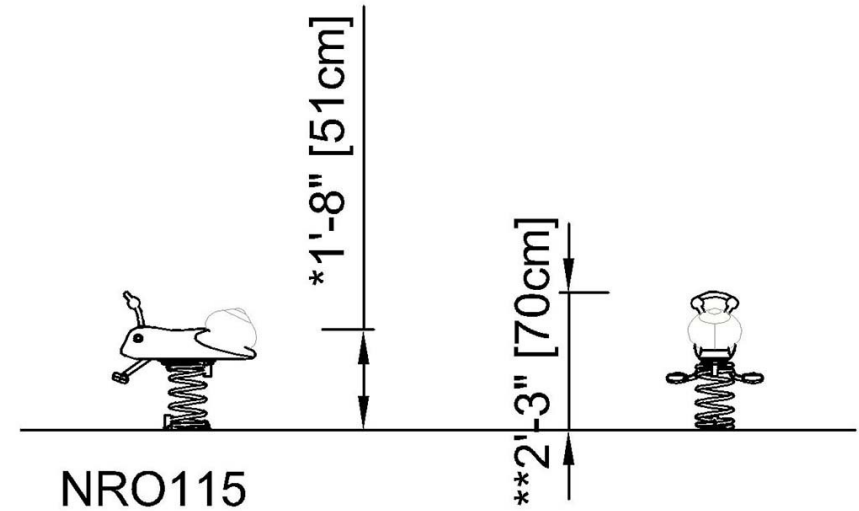
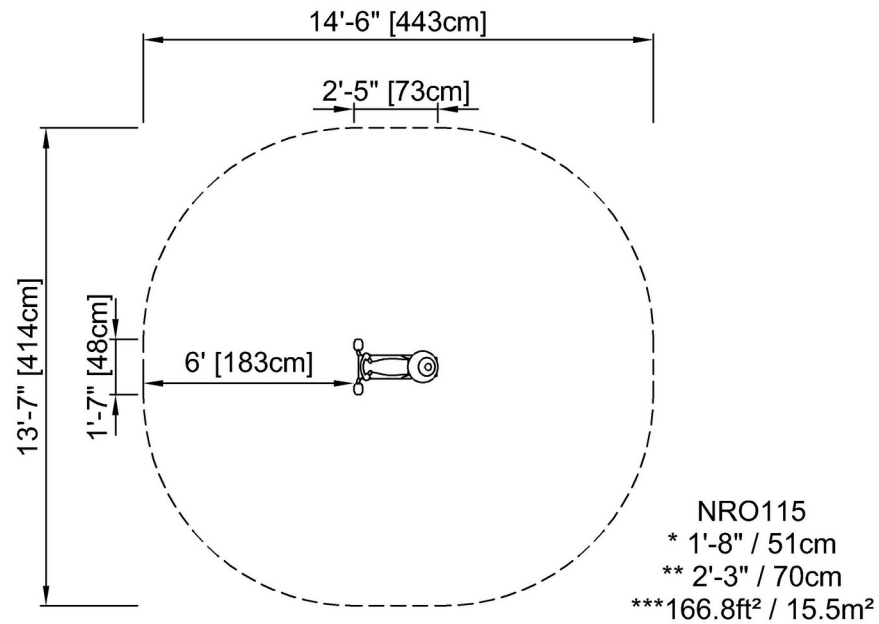

[Click to see TOP VIEW](#)

[Click to see SIDE VIEW](#)