

Shop & Kitchen

MSV603

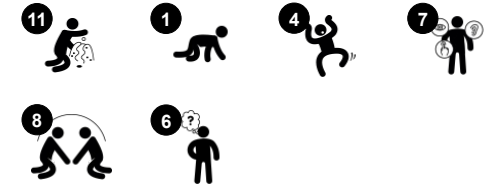

Item no. MSV60300-0201	
General Product Information	
Dimensions LxWxH	145x120x121 cm
Age group	6m - 4
Play capacity (users)	8
Colour options	



Wow! This is the perfect structure for the classic themes of Shop and Kitchen. There is so much to do in such a small space! Children will play for hours, time and time again, with the varied and interesting play activities. These benefit the children's physical, social-emotional, cognitive, and creative development. Numerous play features motivate

social play and support child development: The con-veyor belt and oven transport materials through, encouraging social interaction. The Shop side has tangible themes: microphone, switch and money desk. The Kitchen side has oven and cooker. The pushing, pulling and investigation of the numerous play items stimulate the child's logical thinking skills. The

rich themes in- spire dramatic play, which is phenomenal for language development: a main factor for learning, friendships and life success.



Shop & Kitchen

MSV603



Bell

Cognitive: understanding cause and effect when ringing bell. **Creative:** leaving a mark in creating a sound rhythm when ringing or knocking the bell.



Microphone

Cognitive: inspires dramatic play which stimulates language development. Cause and effect understanding is supported when discovering that the microphone can be shifted to different positions. **Creative:** positioning the microphone in different positions can support symbolic thinking.



Funnel

Social-Emotional: trains cooperation and turn-taking as children put materials into the funnel. **Cognitive:** the passing of materials through funnels supports the children's logical thinking and for younger children the understanding of object permanence: that materials don't vanish but run through at the other end.



Clock

Cognitive: learning about numeracy and time in a tangible way. **Creative:** leaving your mark on the playground when setting clock differently.



Crawl-through hole

Physical: the hole allows for climbing and crawling through, developing cross coordination, proprioception and spatial awareness. **Social-Emotional:** cooperation and turn-taking when passing one another. **Cognitive:** understanding space, shape and measures when seeing if the body can fit through the hole.



Conveyor belt

Physical: tactile stimulation from running hands over rolling spheres on conveyor belt. **Social-Emotional:** spurs group play and conversations with its two-sidedness. **Cognitive:** understanding of object permanence when pictures roll away and reappear.



Pot

Cognitive: the pot can be removed, stimulating cause and effect understanding. Filling and emptying the pot stimulates logical thinking and the understanding of concepts such as empty and full. **Creative:** placing the pot in other areas of the play space in creative ways can support symbolic and creative thinking.

Shop & Kitchen

MSV603



Panels of 19mm EcoCore™. EcoCore™ is a highly durable, eco friendly material, which is not only recyclable after use, but also consists of material produced from +95% recycled post consumer material from food packing waste.



Sand Pipe is made with 33% post-consumer materials in different colors in one-piece design with a wall thickness of minimum 5mm. Material in accordance with the European Standard EN 71-3 and tested for UV stability.



Pots are made of pressure moulded high quality nylon (PA6). PA6 has good wearing and impact strength.

Item no. MSV60300-0201

Installation Information

Max. fall height	0 cm
Safety surfacing area	0.0 m ²
Total installation time	6.3
Excavation volume	0.00 m ³
Concrete volume	0.00 m ³
Footing depth (standard)	0 cm
Shipment weight	49 kg
Anchoring options	Surface ✓

Warranty Information

EcoCore HDPE	Lifetime
Membrane	2 years
Movable parts	2 years
PUR components	10 years
Spare parts guaranteed	10 years

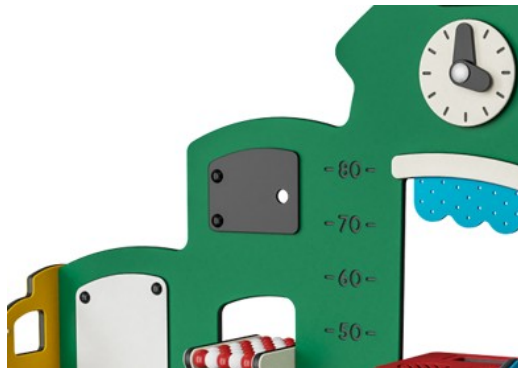

Membranes consist of friction-proof rubberized material of conveyor belt quality with excellent UV resistance. Embedded is a four-layered armouring made of woven polyester. The armouring and the two surface layers result in a total thickness of 7 mm.



Microphone is made of PC and fitted on a flexible shaft of POM material.

Elevated activities 0	Accessible elevated activities	Accessible ground level activities	Accessible ground level play types
Present	0	1	1
Required	0	1	1



Sustainability Data

MSV603



Cradle to Gate A1-A3	Total CO ₂ emission	CO ₂ e/kg	Recycled materials
	kg CO ₂ e	kg CO ₂ e/kg	%
MSV60300-0201	65.15	1.41	83.22

The overall framework applied for these factors is the Environmental Product Declaration (EPD), which quantifies "environmental information on the life cycle of a product and enable comparisons between products fulfilling the same function" (ISO, 2006). This follows the structure and applies a Life-Cycle Assessment approach to the entire Product stage from raw material through manufacturing (A1-A3))

Kompan A/S
 C.F. Tietgens Boulevard 32C
 DK-5220 Odense SØ
 Denmark



Verification of CO₂ calculation of: Themed play systems



Data version no. 2023-10-05

The CO₂ calculation and data are in compliance with the principles of a carbon footprint impact according to the GHG protocol (Greenhouse Gas Protocol), Scope 3, cradle to gate related to all individual components in the product category: "Themed play systems" represented by item no.: MSC641100-3717P.

(Scope 3 emissions include emission sources in the upstream and downstream value chain).

Date: 30. October 2023 | Valid until: 30. October 2025

Verified by:

Julie Marie Vejsgaard Larsen, LCA & EPD Consultant

Verification based on report: Validation of CO₂ calculation of 9 categories of Kompan product line, version 1.0, prepared by: Bureau Veritas HSE, Denmark: Julie M. V. Larsen.

Publication date: 30. October 2023

By Bureau Veritas HSE
 www.bureauveritas.dk
 +45 7731 1000



Shop & Kitchen

MSV603

* Max fall height | ** Total height | *** Safety surfacing area

* Max fall height | ** Total height

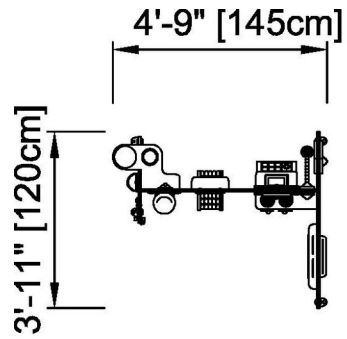

MSV60300-0201

** 4' / 121cm
1/8" = 1'-0"



MSV60300

[Click to see TOP VIEW](#)

[Click to see SIDE VIEW](#)