

Pull Down

FSW40400

KOMPAN



Item no. FSW40400-0001	
General Product Information	
Dimensions LxWxH	125x212x179 cm
Age group	
Capacity (users)	1
Colour options	



With adjustable load, the Pull Down provides targeted weight training for the upper back and biceps. The user-friendly handles with multi-function grips allow for various exercise variations and perfect ergonomics. No seat adjustment is necessary, as the thigh support is designed to fit users of all sizes comfortably. All mechanical stops are placed inside the

cover for maximum safety.



Pull Down

FSW40400



All mechanical stops are fully enclosed within the cover. The adjustable weight, featuring internal end stops and indexed positions, moves on rollers within an enclosed groove in an aluminium profile. As a result, entrapment is not possible, making it extremely safe to use and providing protection against the elements and unwanted abuse.



The weight on each side can be adjusted in 8 steps of 5 kg, providing a training weight from 10 to 80kg. The patent pending system is intuitive to use, eliminating the need for traditional pins that can get lost or stuck. Pull the handle and move the weight to quickly select the desired load.



The seat is made of blowmolded PE and mounted directly onto the steel frame, making it highly durable and resistant to wear and tear. To ensure comfort and a great user experience, the seat features an ergonomic groove. A seat height of 43 cm ensures easy access and transfer for wheelchair users.



The machine features low operating noise thanks to an internal end stop made from TPE (thermoplastic elastomer). The damper absorbs impact energy from the weight with minimal rebound, reducing noise and vibration and ensuring a quieter, more controlled training experience.



Handles
The ergonomically shaped handles feature multiple grip areas to support adaptable training. This allows users between 140–205 cm in height to perform exercises with correct ergonomics while enabling a wide variety of exercises that target different muscle groups. The handles are made from cast aluminium with a grip texture finish.

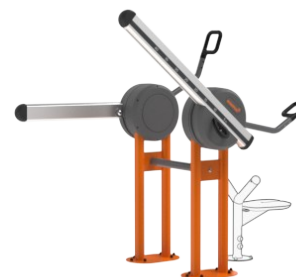

The unilateral movement design ensures that each arm works independently, preventing compensation by the stronger side. The independent movement also allows for greater flexibility, enabling multiple exercise variations and supporting inclusive training for users of different abilities.

Item no. FSW40400-0001

Installation Information

Max. fall height	43 cm
Safety surfacing area	19.9 m ²
Total installation time	6.4 hours
Excavation volume	0.00 m ³
Concrete volume	0.00 m ³
Footing depth (standard)	0 cm
Shipment weight	347 kg
Anchoring options	

Warranty Information

Galvanised/painted metal	10 years
Aluminum	15 years
Movable Parts	2 years
Hollow PE parts	10 years
Spare Parts Guarantee	10 years

Sustainability Data

FSW40400



Cradle to Gate A1-A3	Total CO ₂ emission	CO ₂ e/kg	Recycled material
	kg CO ₂ e	kg CO ₂ e/kg	%
FSW40400-0001	1,389.70	6.28	45.20

The overall framework applied for these factors is the Environmental Product Declaration (EPD), which quantifies "environmental information on the life cycle of a product and enable comparisons between products fulfilling the same function" (ISO, 2006). This follows the structure and applies a Life-Cycle Assessment approach to the entire Product stage from raw material through manufacturing (A1-A3))



Independent review certificate

Kompan A/S
C. F. Tietgens Blvd. 32C, 5220 Odense SØ

Bureau Veritas hereby attests that the CO₂e-calculations (covering materials, processing, waste and transport) done by Kompan for "Fitness", meet the requirements set by the listed standard.

Kompan A/S uses a selection of EPDs and emission factors from the Life Cycle Assessment database Ecoinvent 3.11. These values are reported as kg CO₂e, with all other impact categories excluded in line with the scope of ISO 14067:2018. The emission factors cover, material use, manufacturing processes, transport to Kompan, and electricity used during manufacturing. The presented emissions fall under GHG Protocol scope 3 emissions. Scope 1 and 2 are not presented. Scope 3 emissions include emission sources in the upstream value chain of a company, downstream emissions are excluded in this analysis.

Method: ISO 14067:2018 using GHG protocol guidance documents, reported as kg CO₂e.

Object

The verification has been done on the one pager "FAZ10100-0900" version: 27-10-2025. The supporting documentation "KOMPAN data_updated emissions factors_2025_V2" and "Emissions factors, EPD's and ecoinvent 3.11_2025" was also reviewed and approved.

Declaration

The review has been completed as a critical review with a limited assurance. I hereby confirm that nothing has come to the reviewer's attention which would lead to conclude that the study does not give an accurate depiction or isn't completed following method of the CO₂e calculation, the requirements of ISO 14067:2018, and 14071:2024, in the above referenced documentation.

Note: This verification only covers calculation elements according to method described in ISO 14067:2018 and may not be seen as a Life Cycle Assessment according to ISO 14067:2018.

Ref.: Kompan_Verification report 2025, 28-10-2025

Date of certificate: 29-10-2025

Expire date: 29-10-2027

Verified by: Julie Marie Vejsgaard Larsen, Environmental Auditor

Signature:

Pull Down

FSW40400

* Max fall height | ** Total height | *** Safety surfacing area

* Max fall height | ** Total height

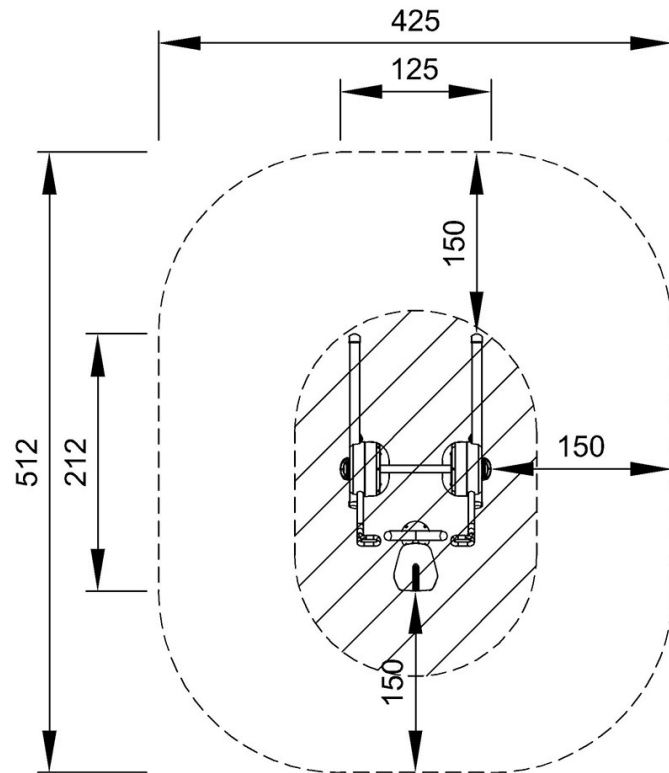

FSW40400
*43cm
**179cm
***19.9m²

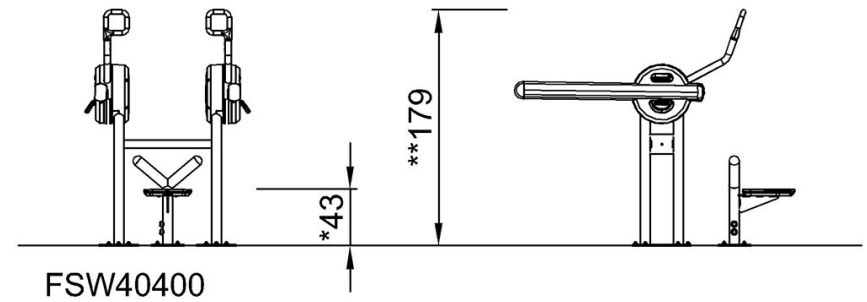

[Click to see TOP VIEW](#)

[Click to see SIDE VIEW](#)