

Double Cableway for Flat Area

M88112

Item no. M88112-3817

General Product Information

Dimensions LxWxH	3359x562x397 cm
Age group	4+
Play capacity (users)	2
Colour options	●

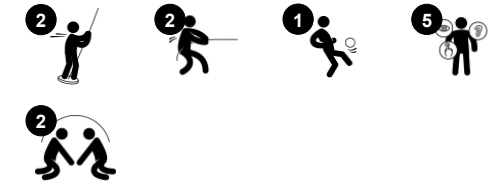
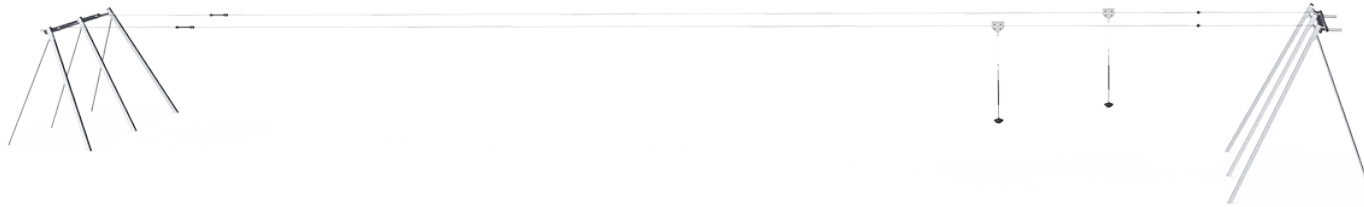

The Double Flying Fox/Cableway is the ultimate social daredevil attraction. It will support social play, again and again, children racing each other to the end, competing speed as they go. And they will go, again and again. The reason for this solid holding power lies mainly in the immense thrill of gliding through the air. The feeling of weightlessness and the

swooshing through the air trains spatial awareness as well as the child's understanding of gravity, space, and speed. This is necessary e.g. in managing traffic safely. The social skills get trained as children diligently hand back the seat to the next user in line. The running and pulling involved in this train the child's cardio as well as upper body muscles. All in all, the large

cableway is an asset of play that unites generations and abilities as there is some way for almost everyone to use it.



Double Cableway for Flat Area

M88112



Dino seat

Physical: the three divisions and chains of the seat provide efficient handholds for both standing and seated swinging. **Social-Emotional:** the possibility of children swinging together, legs hanging down, trains cooperation, sequencing and turn-taking when swinging.

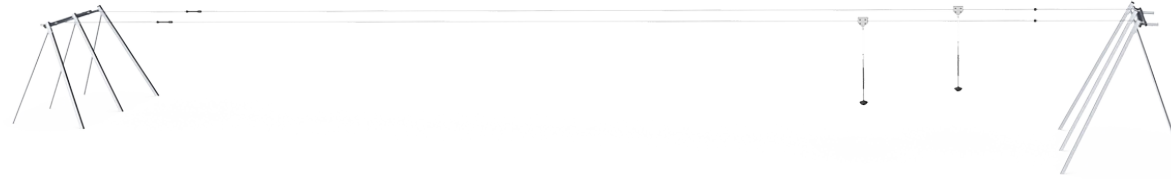

Long line

Physical: the lengthy glide through the air adds to the thrill and trains spatial awareness, trunk stability and upper-body muscles. All this helps support the child's physical self esteem, making e.g. positive risk taking easier.



PUR covered rope

Physical: firm grip when spinning and hanging from arms. Arm muscles developed when held tight.



Double zipline

Social-Emotional: the possibility to glide with a companion or have friendly competitions supports turn taking and cooperation skills. **Cognitive:** the speed may differ between the two zip lines. Figuring out the reason behind this (weight, speed, force etc.) trains logical thinking.

Double Cableway for Flat Area

M88112



The steel support posts are hot-dip galvanized inside and outside with lead free zinc. The galvanisation has excellent corrosion resistance in outside environments and requires low maintenance.



The specially designed seat is made from a stainless-steel insert covered with a soft layer of PUR rubber. The seat is impact tested to comply with global playground standards, and the rope has an ergonomic handhold of a 100cm long moulded on PUR rubber handle.



The high-quality steel cable with a diameter of 12mm is designed for heavy usage of the cableway for many years. The starting point is indicated by a knob. At the stop point, there is a uniquely designed spring device, ensuring a softer stop of the puller.

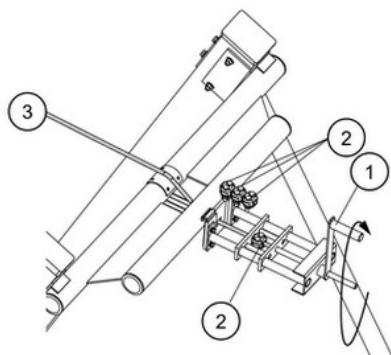

The steel cable three is tensioned by a specially designed device. By turning the handle, the steel cable can be tensioned safely. After tensioning the cable is locked by three clamps. The tensioning device can also be used for adjustment during annual inspections.

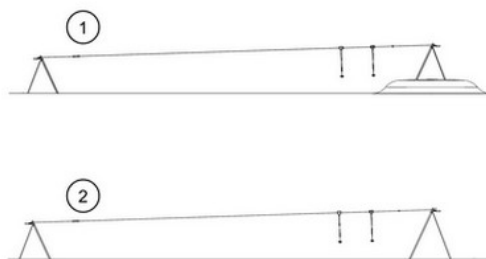

KOMPAN cableways are available for flat or natural sloped surroundings and for surface or in-ground installation. Further, the cableways can be supplied with one or two cables for children to ride together in friendly competition.

Item no. M88112-3817

Installation Information

Max. fall height	100 cm
Safety surfacing area	182.0 m ²
Total installation time	18.3
Excavation volume	12.28 m ³
Concrete volume	3.95 m ³
Footing depth (standard)	100 cm
Shipment weight	758 kg
Anchoring options	In-ground ✓

Warranty Information

Cable	10 years
Galvanised Steel	Lifetime
Movable Parts	2 years
PUR Components	10 years
Spare Parts Guarantee	10 years



Sustainability Data

M88112



Cradle to Gate A1-A3

Total CO ₂ emission	CO ₂ e/kg	Recycled materials
kg CO ₂ e	kg CO ₂ e/kg	%
M88112-3817	1,974.20	2.60
		49.79

The overall framework applied for these factors is the Environmental Product Declaration (EPD), which quantifies "environmental information on the life cycle of a product and enable comparisons between products fulfilling the same function" (ISO, 2006). This follows the structure and applies a Life-Cycle Assessment approach to the entire Product stage from raw material through manufacturing (A1-A3))

Kompan A/S
 C.F. Tietgens Boulevard 32C
 DK-5220 Odense SØ
 Denmark



Verification of CO₂ calculation of: Freestanding play equipment



Data version no. 2023-10-05

The CO₂ calculation and data are in compliance with the principles of a carbon footprint impact according to the GHG protocol (Greenhouse Gas Protocol), Scope 3, cradle to gate related to all individual components in the product category: "Freestanding play equipment" represented by item no.: KSW92011-0910.

(Scope 3 emissions include emission sources in the upstream and downstream value chain).

Date: 30. October 2023 | Valid until: 30. October 2025

Verified by:

Julie Marie Vejsgaard Larsen, LCA & EPD Consultant

Verification based on report: Validation of CO₂ calculation of 9 categories of Kompan product line, version 1.0, prepared by: Bureau Veritas HSE, Denmark: Julie M. V. Larsen.

Publication date: 30. October 2023

By Bureau Veritas HSE
 www.bureauveritas.dk
 +45 7731 1000



Double Cableway for Flat Area

M88112

* Max fall height | ** Total height | *** Safety surfacing area

* Max fall height | ** Total height

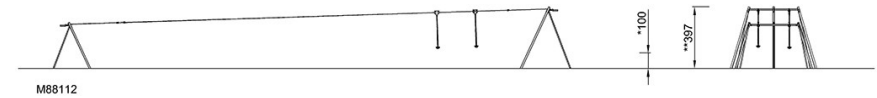
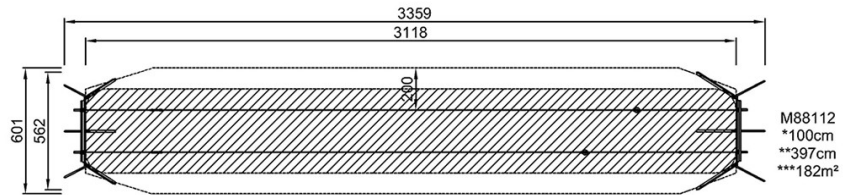

[Click to see TOP VIEW](#)

[Click to see SIDE VIEW](#)