

Giant Dino Swing

M986

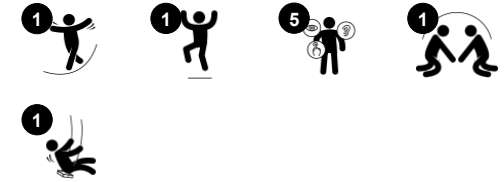

Item no. M98601-1401	
General Product Information	
Dimensions LxWxH	478x123x371 cm
Age group	6+
Play capacity (users)	7
Colour options	



The Giant Dino Swing will attract children time and time again. The multiple directions, and ability to swing at great heights, provide thrill and fun. The bird's nest seat has room for more children to be seated or standing while swinging, making it a sociable and fun experience. It teaches children to take turns and cooperate. The seat can also be used

individually for a more relaxing swing. The seat caters to all abilities and most ages, meaning swinging can be a common experience. The movements cause both thrill, laughter, and relaxation. The swinging movement trains children's sense of balance and space, fundamental for spatial judgment and body awareness. Swinging the seat trains arm, leg,

and core muscles, while jumping off builds bone density. The Giant Dino Swing thus develops children in fun and social play.



Giant Dino Swing

M986



Bird nest swing

Physical: develops balance, coordination and spatial awareness. The swinging movement trains the arm, leg and core muscles, and strengthens bone density when jumping off. **Social-Emotional:** the spacious seat allows for many children standing, lying, seated together and is inclusive for all. **Cognitive:** cause and effect understanding, rhythm and thinking skills are developed in younger children.



Swinging 360

Physical: the rotating swing movement trains spatial awareness intensely, balance and coordination are further developed. **Social-Emotional:** cooperation and empathy are trained when cooperating on directions of swinging. **Cognitive:** figuring out how to use your body to navigate the swing in different directions is a great trainer of embodied cognition.

Giant Dino Swing

M986



The steel surfaces are hot dip galvanised inside and outside with lead free zinc. The galvanisation has excellent corrosion resistance in outside environments and requires low maintenance.

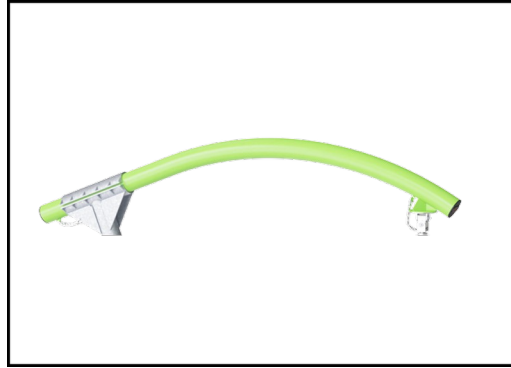

Powder coated top finish on top of galvanisation is processed in two steps: Light grinding and clean sweeping, powder coating - thickness 70-120 µm.



Unique designed 360-degree rotating swing hanger made of stainless steel. The moving parts of the swing hanger is lifetime sealed and lubricated. The hanger system is equipped with a safety chain to prevent the swing hanger to fall down if damaged.



KOMPAN designed the bird's nest seats to be light in weight and in compliance with global safety standards. The soft, shock absorbent bumpers with non-slip surface makes the swing seat extremely user friendly. Choose between a rope version with reinforced PA rope or a moulded PE version. Both equipped with soft rubber bumpers.



The seat suspensions are available in stainless steel chain or rope. The ropes are made of UV-stabilised PA with inner steel cable reinforcement. The rope is induction treated in order to create a strong connection between steel and rope which leads to good wear resistance.



The Giant Swing is available in multiple combinations through the digital KOMPAN product configurator: Galvanised steel with optional powder coated top finish in lime green colour, Rope or stainless-steel chain suspensions, In-ground or surface anchoring and rope or shell Birds Nets seat

Item no. M98601-1401

Installation Information

Max. fall height	180 cm
Safety surfacing area	61.4 m ²
Total installation time	8.9
Excavation volume	3.58 m ³
Concrete volume	2.56 m ³
Footing depth (standard)	140 cm
Shipment weight	692 kg
Anchoring options	In-ground ✓

Warranty Information

Hot dip galvanised steel	Lifetime
Ropes & nets	10 years
Spare parts guaranteed	10 years
Swing hangers	5 years
Swing seat	10 years

**EN
1176**
compliant

Sustainability Data

M986



Cradle to Gate A1-A3	Total CO ₂ emission	CO ₂ e/kg	Recycled materials
	kg CO ₂ e	kg CO ₂ e/kg	%
M98601-1401	1,493.01	2.77	48.33

The overall framework applied for these factors is the Environmental Product Declaration (EPD), which quantifies "environmental information on the life cycle of a product and enable comparisons between products fulfilling the same function" (ISO, 2006). This follows the structure and applies a Life-Cycle Assessment approach to the entire Product stage from raw material through manufacturing (A1-A3))

Kompan A/S
 C.F. Tietgens Boulevard 32C
 DK-5220 Odense SØ
 Denmark



Verification of CO₂ calculation of: Freestanding play equipment



Data version no. 2023-10-05

The CO₂ calculation and data are in compliance with the principles of a carbon footprint impact according to the GHG protocol (Greenhouse Gas Protocol), Scope 3, cradle to gate related to all individual components in the product category: "Freestanding play equipment" represented by item no.: KSW92011-0910.

(Scope 3 emissions include emission sources in the upstream and downstream value chain).

Date: 30. October 2023 | Valid until: 30. October 2025

Verified by:

Julie Marie Vejsgaard Larsen, LCA & EPD Consultant

Verification based on report: Validation of CO₂ calculation of 9 categories of Kompan product line, version 1.0, prepared by: Bureau Veritas HSE, Denmark: Julie M. V. Larsen.

Publication date: 30. October 2023

By Bureau Veritas HSE
 www.bureauveritas.dk
 +45 7731 1000



Giant Dino Swing

M986

* Max fall height | ** Total height | *** Safety surfacing area

* Max fall height | ** Total height

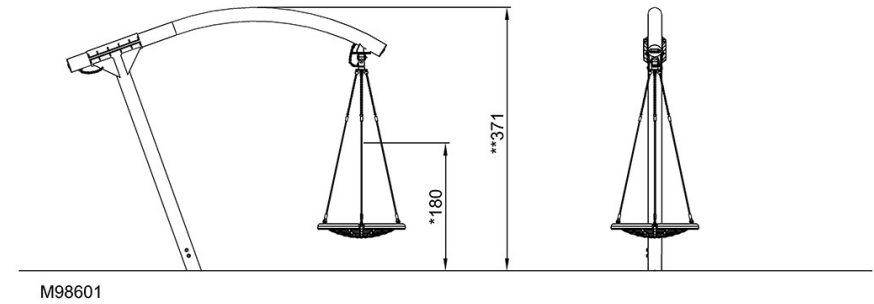
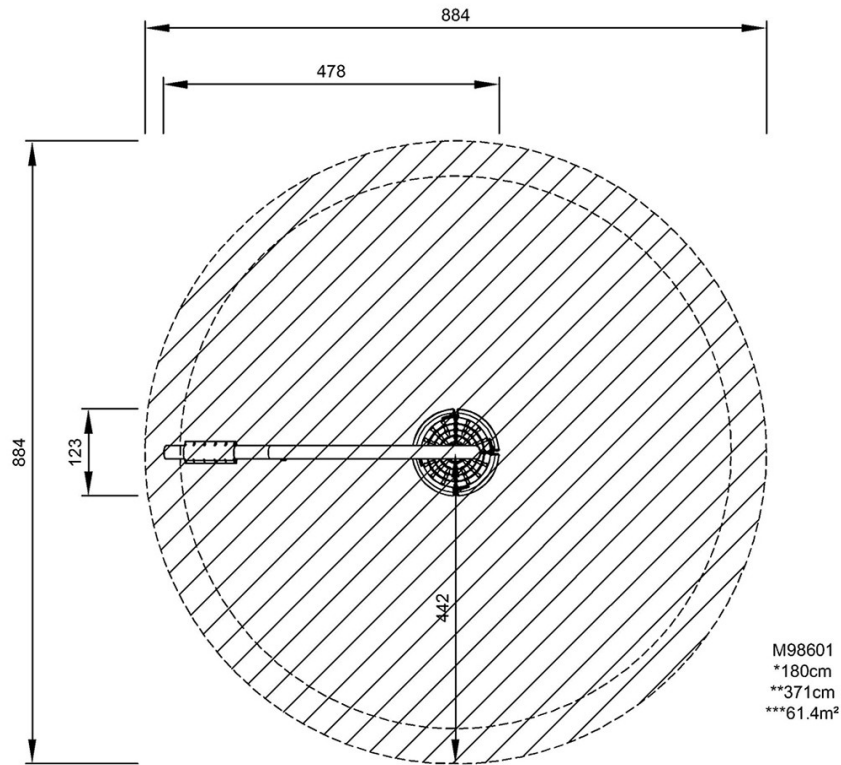

[Click to see TOP VIEW](#)

[Click to see SIDE VIEW](#)