

# Miracle Sphere

COR88100

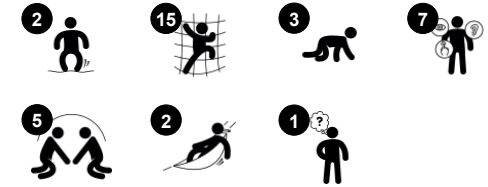

Item no. COR881001-0402	
<b>General Product Information</b>	
Dimensions LxWxH	400x400x330 cm
Age group	5+
Play capacity (users)	32
Colour options	



The eight-legged, spider-like Miracle Sphere is a popular playscape keeping children occupied for hours with its webs of diverse climbing opportunities. The swaying ropes, nets and rubber ladders offer fun climbing challenges to the vertical top net. With its spread out access points to the top net, the Miracle Sphere caters for a lot of children in fun play at the same time.

Apart from being great fun, the Miracle Sphere offers ample training of all major muscles and fundamental motor skills. All muscles are in use when clinging on to the ropes or climbing up high. Important motor skills such as cross-body coordination and spatial awareness are used. These skills are fundamental e.g. when judging distances and managing traffic securely. The

horizontal top net is a great venue for meeting friends, socialising and helping one another up find a way up to chill and enjoy the view.

# Miracle Sphere

COR88100



## Horizontal net

**Physical:** cross coordination is developed when climbing over and sense of space when looking down. **Social-Emotional:** space for socialising and bouncy breaks.



## Big meshes

**Physical:** the big meshes allow for climbing and crawling, supporting proprioception, cross coordination and spatial awareness. **Social-Emotional:** allow more children being seated together, sharing.



## Connected nets

**Physical:** the connected nets make the climbers feel the movements of the other climbers. All muscle groups are trained, as well as cross coordination. **Social-Emotional:** the climbers' movements affect the other climbers, so consideration and turn-taking is supported.



## Vertical side ropes with steps

**Physical:** children develop cross-body coordination and muscle strength when using the rope to climb the steps. Their sense of balance is trained when swaying gently. **Social-Emotional:** turn-taking when children pass each other.



## Membrane loops

**Physical:** develops leg, arm and core muscles as well as motor skills such as cross coordination and proprioception. **Social-Emotional:** showing consideration of others and helping others when passing one another going up or down.



## Transparency

**Social-Emotional:** the transparency makes cooperation and communication possible, which are essential life skills for children to learn.



## Rope with rubber disc

**Physical:** children develop cross-body coordination and muscle strength when climbing the rope. Their sense of balance is trained when swaying gently. **Social-Emotional:** socialising and turn-taking when deciding who should sit here.

# Miracle Sphere

COR88100



Corocord membranes consist of friction-proof rubberised material of conveyor belt quality with excellent UV resistance. Tested and compliant with REACH requirements for PAH. Embedded is a four-layered armouring made of woven polyester. The armouring and the two surface layers result in a total thickness of 7.5 mm.



Corocord aluminium clamps are used as connectors between steel posts and rope. The aluminium casting is screwed into the steel post and connects safely to the rope.



Fully coloured EPDM rubber discs with smooth surface. The moulded EPDM surrounds a hot-dip galvanised steel core that ensures both the stability of the discs and durable fixtures to the rope.



Corocord ropes with 19mm+ diameter are known as a 'Hercules' rope type which is formed from galvanised six-stranded steel wires. Each strand is tightly wrapped with PES yarn, which is melted onto each individual strand. Ropes are highly wear-and vandalism-resistant and can be easily replaced on-site if needed.



Designed to allow the typical function of rope play structures to move Corocord 'S' clamps are used as universal connections in Corocord products. 8mm stainless steel rods with rounded edges are pressed around the ropes with a special hydraulic press, making them the ideal connector. Our clamps are safe, durable and vandalism-proof.

Item no. COR881001-0402

## Installation Information

Max. fall height	240 cm
Safety surfacing area	48.5 m <sup>2</sup>
Total installation time	27.1
Excavation volume	6.32 m <sup>3</sup>
Concrete volume	2.43 m <sup>3</sup>
Footing depth (standard)	65 cm
Shipment weight	1,076 kg
Anchoring options	In-ground ✓

## Warranty Information

Aluminium Clamps	10 years
Corocord (Hercules) Rope	10 years
Membrane	2 years
S-Clamps	10 years
Spare Parts Guarantee	10 years





# Sustainability Data

COR88100

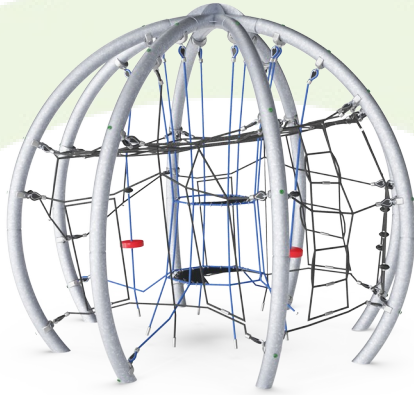

Cradle to Gate A1-A3	Total CO <sub>2</sub> emission	CO <sub>2</sub> e/kg	Recycled materials
	kg CO <sub>2</sub> e	kg CO <sub>2</sub> e/kg	%
<b>COR881001-0402</b>	2,889.58	3.16	47.05

The overall framework applied for these factors is the Environmental Product Declaration (EPD), which quantifies "environmental information on the life cycle of a product and enable comparisons between products fulfilling the same function" (ISO, 2006). This follows the structure and applies a Life-Cycle Assessment approach to the entire Product stage from raw material through manufacturing (A1-A3))

**Kompan A/S**  
 C.F. Tietgens Boulevard 32C  
 DK-5220 Odense SØ  
 Denmark



## Verification of CO<sub>2</sub> calculation of: Corocord

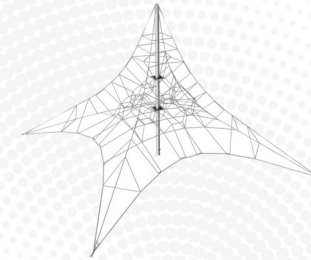

Data version no. 2023-10-05

The CO<sub>2</sub> calculation and data are in compliance with the principles of a carbon footprint impact according to the GHG protocol (Greenhouse Gas Protocol), Scope 3, cradle to gate related to all individual components in the product category: "Corocord" represented by item no.: COR314011-1101.

(Scope 3 emissions include emission sources in the upstream and downstream value chain).

**Date: 30. October 2023 | Valid until: 30. October 2025**

Verified by:

Julie Marie Vejsgaard Larsen, LCA & EPD Consultant

Verification based on report: Validation of CO<sub>2</sub> calculation of 9 categories of Kompan product line, version 1.0, prepared by: Bureau Veritas HSE, Denmark: Julie M. V. Larsen.

**Publication date: 30. October 2023**

By Bureau Veritas HSE  
 www.bureauveritas.dk  
 +45 7731 1000



# Miracle Sphere

COR88100

\* Max fall height | \*\* Total height | \*\*\* Safety surfacing area

\* Max fall height | \*\* Total height

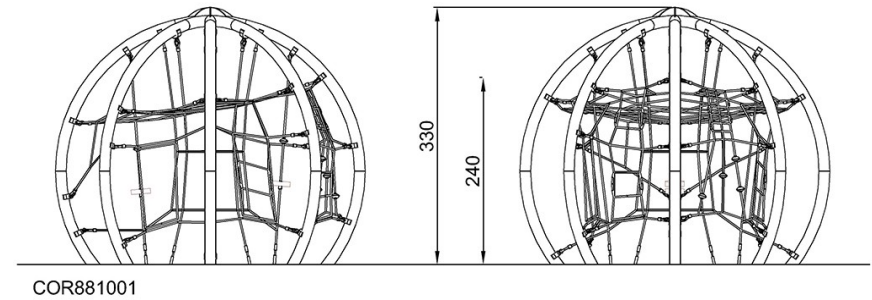
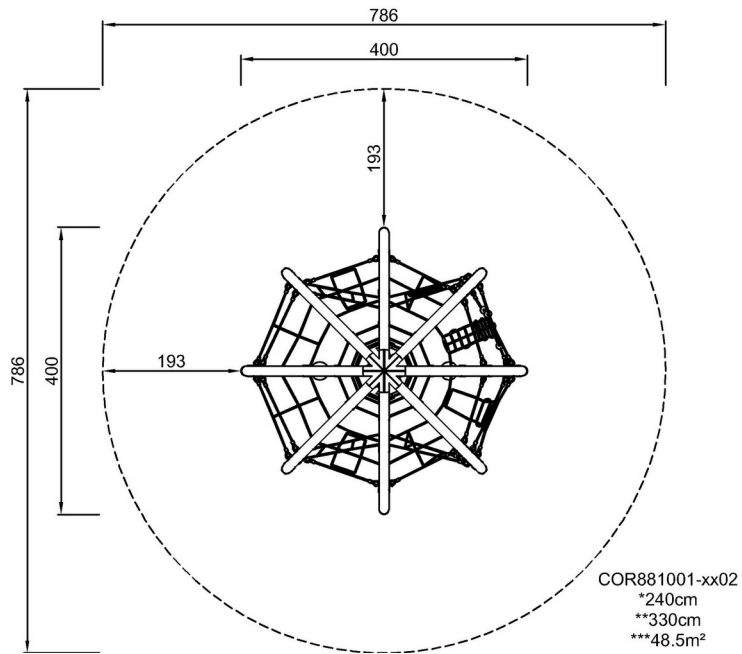

[Click to see TOP VIEW](#)

[Click to see SIDE VIEW](#)