

Digger with Slide

PCM51221

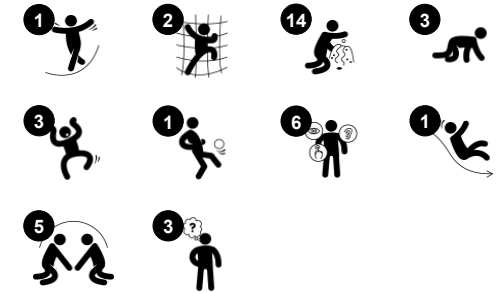

Item no. PCM51221-0901	
General Product Information	
Dimensions LxWxH	441x180x276 cm
Age group	2+
Play capacity (users)	17
Color options	



The Digger is a great attractor of dramatic and fun physical play for younger children. The rich variety of manipulative activities both on elevated and ground level support the dramatic play scenarios. We know from our KOMPAN Play Institute studies, that manipulative play elements increase the play retention, as well as the dramatic play in very young children. This

supports language skills and communication, helping children to understand the world. And not least to be understood by the surroundings. Rich climb, crawl and slide activities attract hugely and ensures physical activity that trains important motor skills and major muscles. Multiple varied climbs up and crawls through holes ensure ample training of the cross-body

coordination which builds body confidence and ultimately stimulate the cross-modal perception. This supports for instance reading skills. Dramatic play is the favorite play type for younger children. In the case of the Digger, story telling themes of all kinds can be put to play.

Digger with Slide

PCM51221



Tic-tac-toe panel

Social-Emotional: stimulates communication and turn-taking skills. **Cognitive:** support rules understanding, strategic thinking. **Creative:** leaving marks when tumblers are left in new positions.



Turning wheel

Cognitive: the manipulative item stimulates cause and effect understanding.



Megaphone

Social-Emotional: inspires communication and turn-taking skills. **Cognitive:** distortion of sound evokes curiosity and stimulates an understanding of cause and effect.



Rock climber

Physical: supports cross coordination and leg, arm and hand strength. **Social-Emotional:** the inclination makes climbing feel secure, especially for younger children.

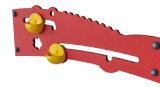

Sand scoops

Physical: hand eye coordination and push-pull movements. **Social-Emotional:** invites cooperation due to the two-sidedness and provides for parallel play. **Cognitive:** logical thinking: cause and effect understanding when running scoops in grooves or shifting materials from scoop to scoop. **Creative:** shifting scoops, creating new scoop positions.



Slide

Physical: sliding develops spatial awareness and a sense of balance. Furthermore, the core muscles are trained when sitting upright going down. **Social-Emotional:** empathy stimulated by turn-taking. **Cognitive:** young children develop their understanding of space, speed and distances when sliding down quickly.



Theme

Cognitive: suggests a theme and supports dramatic play, which stimulates language and communication skills.

Digger with Slide

PCM51221



Panels of 19mm EcoCore™. EcoCore™ is a highly durable, eco friendly material, which is not only recyclable after use, but also consists of material produced from +95% recycled post consumer material from food packing waste.



Main posts with hot dip galvanised steel footing are pre-galvanised inside and outside with powder coated top finish.



All decks are supported by unique designed low-carbon aluminum profiles with multiple attachment options. The grey colored molded decks are made of 75% post-consumer waste PP material with a non-skid pattern and texture surface.

Item no. PCM51221-0901

Installation Information

Max. fall height	118 cm
Safety surfacing area	28.3 m ²
Total installation time	23.7
Excavation volume	0.61 m ³
Concrete volume	0.48 m ³
Footing depth (standard)	90 cm
Shipment weight	684 kg
Anchoring options	In-ground ✓ Surface ✓



The steel surfaces are hot dip galvanized inside and outside with lead free zinc. The galvanization has excellent corrosion resistance in outside environments and requires low maintenance.



The slides are available in either molded PE made from 33% recycled post-consumer materials in different colors or in full AISI304 stainless steel with a thickness of 2mm.



Gear shift is made of PP. PP has good wearing and impact resistance.



Sustainability Data

PCM51221



Cradle to Gate A1-A3	Total CO ₂ emission	CO ₂ e/kg	Recycled materials
	kg CO ₂ e	kg CO ₂ e/kg	%
PCM51221-0901	1,056.77	2.15	64.71

The overall framework applied for these factors is the Environmental Product Declaration (EPD), which quantifies "environmental information on the life cycle of a product and enable comparisons between products fulfilling the same function" (ISO, 2006). This follows the structure and applies a Life-Cycle Assessment approach to the entire Product stage from raw material through manufacturing (A1-A3))

Kompan A/S
 C.F. Tietgens Boulevard 32C
 DK-5220 Odense SØ
 Denmark



Verification of CO₂ calculation of: Play systems



Data version no. 2023-10-05

The CO₂ calculation and data are in compliance with the principles of a carbon footprint impact according to the GHG protocol (Greenhouse Gas Protocol), Scope 3, cradle to gate related to all individual components in the product category: "Play systems" represented by item no.: PCM200321-0950.

(Scope 3 emissions include emission sources in the upstream and downstream value chain).

Date: 30. October 2023 | Valid until: 30. October 2025

Verified by:

Julie Marie Vejsgaard Larsen, LCA & EPD Consultant

Verification based on report: Validation of CO₂ calculation of 9 categories of Kompan product line, version 1.0, prepared by: Bureau Veritas HSE, Denmark: Julie M. V. Larsen.

Publication date: 30. October 2023

By Bureau Veritas HSE
 www.bureauveritas.dk
 +45 7731 1000



Digger with Slide

PCM51221

* Max fall height | ** Total height | *** Safety surfacing area

* Max fall height | ** Total height

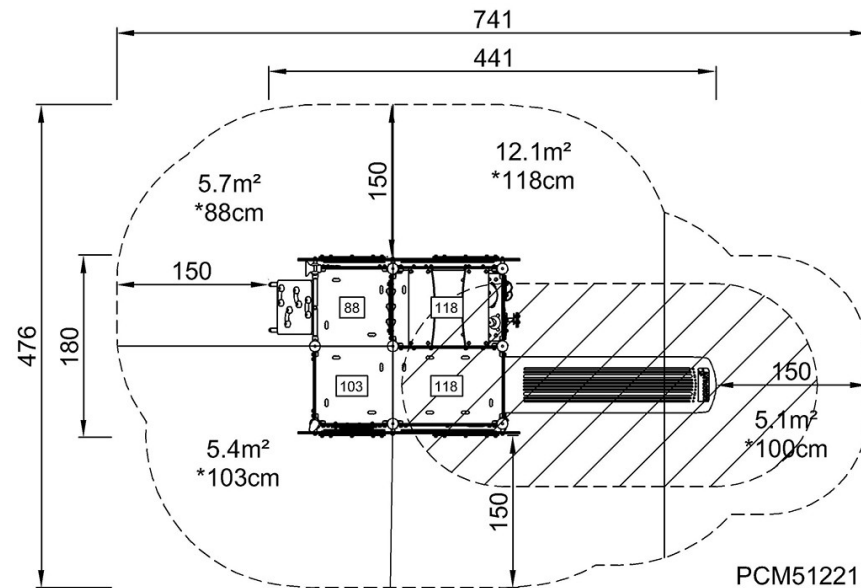

PCM51221
*118cm
**276cm
***28.3m²

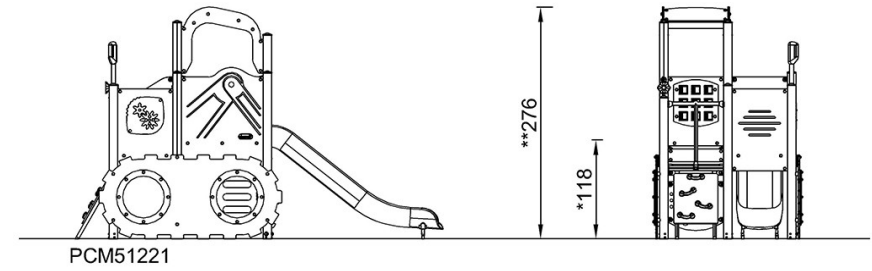

[Click to see TOP VIEW](#)

[Click to see SIDE VIEW](#)