

Double Turbo Challenge Robinia

FRO212

KOMPAN
Let's play



Item no. FRO21200-1001

General Product Information

Dimensions LxWxH	451x126x291 cm
Age group	13+
Play capacity (users)	3
Colour options	



See KOMPAN Fit app for more

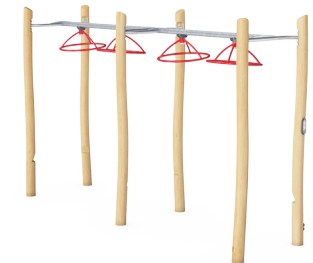

The Turbo Challenge is the most dynamic and thrilling element of all obstacle course exercises. To do the exercise in the best way, a combination of skills, timing, rhythm, and cross-body coordination is needed. This Turbo Challenge is wide and high to ensure anyone can hang and move freely. To make sure that everyone can reach the dynamic wheels there

are 4 steps at different heights. For an optimized and direct swing, the 4 four dynamic wheels have been mounted under a 5-degree angle.

The Robinia bars are made from de-barked and sap-free Robinia trunks in various dimensions. Robinia is a native European wood species with high strength and natural

durability in various climatic conditions. KOMPAN uses wood from FSC-certified sources.

Double Turbo Challenge Robinia

FRO212



All Organic Robinia products by KOMPAN are made of Robinia wood from sustainable European sources. On request it can be supplied as FSC® Certified (FSC® C004450).



The Robinia wood can be supplied as untreated raw wood or painted with a brown coloured transparent pigment that maintains the golden wood colour of the wood.



All KOMPAN fitness products are compliant with the ASTM F3101 & EN16630 Outdoor Fitness Standards. Load tests are performed as a static test by adding dynamic factors as well as safety factors to the specified load of 78kg per user. A product intended for 1 user is loaded with 420kg.

Item no. FRO21200-1001	
Installation Information	
Max. fall height	125 cm
Safety surfacing area	28.0 m ²
Total installation time	8.1
Excavation volume	1.18 m ³
Concrete volume	0.35 m ³
Footing depth (standard)	100 cm
Shipment weight	571 kg
Anchoring options	In-ground ✓ Surface ✓
Warranty Information	
Bearing construction	5 years
Hot dip galvanised steel	Lifetime
Robinia wood	15 years
Spare parts guaranteed	10 years
Wheels	10 years



Overhead Turbo Challenge have a base of hot dip galvanisation and a powder coated top finish. This provides an ultimate corrosion resistance in all climates around the world.



Sustainability Data

FRO212

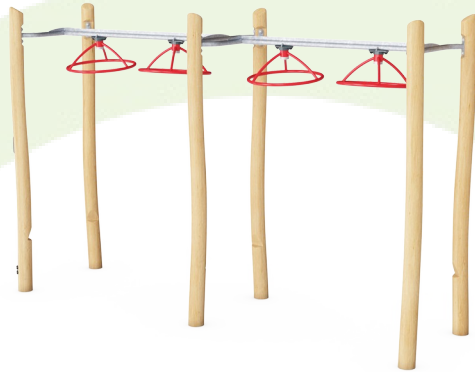

Cradle to Gate A1-A3	Total CO ₂ emission	CO ₂ e/kg	Recycled materials
	kg CO ₂ e	kg CO ₂ e/kg	%
FRO21200-1001	256.00	0.60	9.40

The overall framework applied for these factors is the Environmental Product Declaration (EPD), which quantifies "environmental information on the life cycle of a product and enable comparisons between products fulfilling the same function" (ISO, 2006). This follows the structure and applies a Life-Cycle Assessment approach to the entire Product stage from raw material through manufacturing (A1-A3))

Kompan A/S
 C.F. Tietgens Boulevard 32C
 DK-5220 Odense SØ
 Denmark



Verification of CO₂ calculation of: Fitness



Data version no. 2023-10-05

The CO₂ calculation and data are in compliance with the principles of a carbon footprint impact according to the GHG protocol (Greenhouse Gas Protocol), Scope 3, cradle to gate related to all individual components in the product category: "Fitness" represented by item no.: FAZ10100-0900.

(Scope 3 emissions include emission sources in the upstream and downstream value chain).

Date: 30. October 2023 | Valid until: 30. October 2025

Verified by:

Julie Marie Vejsgaard Larsen, LCA & EPD Consultant

Verification based on report: Validation of CO₂ calculation of 9 categories of Kompan product line, version 1.0, prepared by: Bureau Veritas HSE, Denmark: Julie M. V. Larsen.

Publication date: 30. October 2023

By Bureau Veritas HSE
 www.bureauveritas.dk
 +45 7731 1000



Double Turbo Challenge Robinia

FRO212

* Max fall height | ** Total height | *** Safety surfacing area

* Max fall height | ** Total height

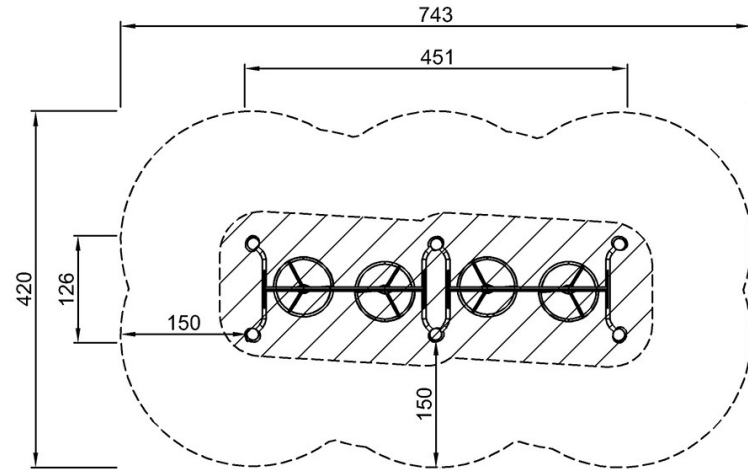

FRO21200
*125cm
**291cm
***28m²

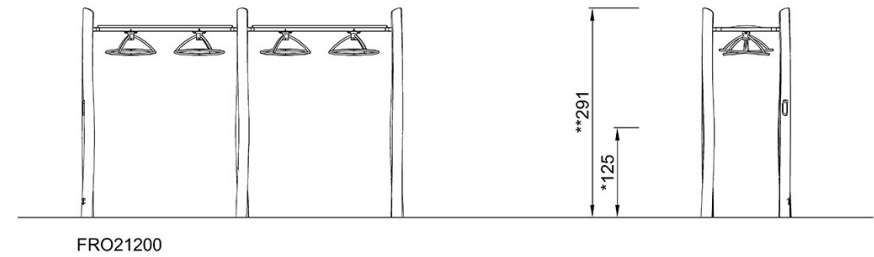

[Click to see TOP VIEW](#)

[Click to see SIDE VIEW](#)