

# Horse, Double

PCM106

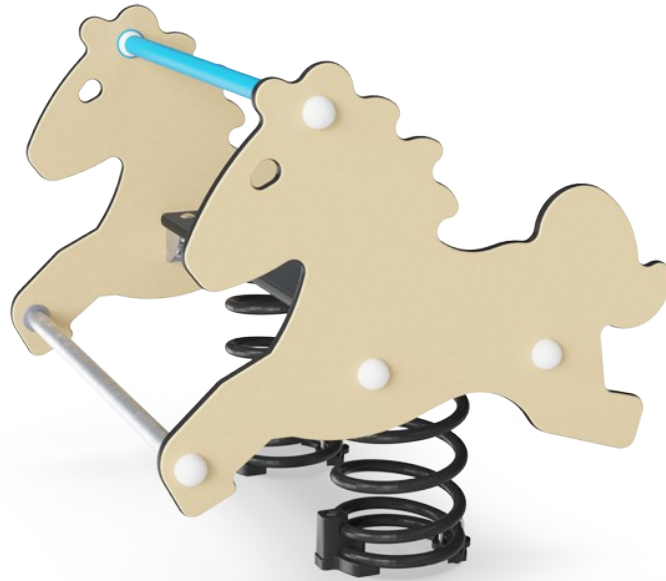

Item no. PCM106-0401

## General Product Information

Dimensions LxWxH	75x72x72 cm
Age group	2 - 5
Play capacity (users)	2
Colour options	



Rocking on the Double Horse is a wildly attractive playground activity. Children are able to control the play by moving their bodies to make the horse rock. They will feel delighted to have the horse respond to their movements. The two sides support the seated position, and the foot and hand holds provide a stable point to stem feet and hands from, to create the

movement. There is room enough for two children on the Double Horse, this creates positive social relations. Rocking on the Double Horse is also good for physical and cognitive development. When children begin to learn the connections between their bodies and their movements, they begin to make cognitive connections to a range of body movements

and sensations. The horse theme will inspire children's imagination, and will encourage wonderful physical and imaginative play.

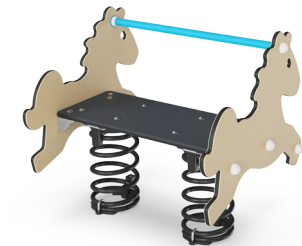

# Horse, Double

PCM106



## Handhold

**Physical:** the vertical handgrips ensure a firm grip at different heights, necessary for rocking intensely. This trains hand and arm muscles.



## Theme

**Cognitive:** suggests a theme and supports dramatic play, which stimulates language and communication skills.



## Foot support

**Physical:** the possibility of footrest supports intensive rocking. Rocking stimulates the senses of balance and space that are fundamental in managing the world securely.



## Rocking spring

**Physical:** response to movements adds to spatial awareness and sense of balance. These are fundamental motor skills that help the child's ability to sit still on a chair which takes a good sense of balance. **Cognitive:** trains the understanding of cause and effect: when I move my body, the spring responds with movement.



## Double seating option

**Social-Emotional:** the possibility of two rocking together supports cooperation skills. Furthermore, the physical contact with others is great for the well-being of children, measurable in lower cortisol (stress hormone) levels.

# Horse, Double

PCM106



Panels of 19mm EcoCore™. EcoCore™ is a highly durable, eco friendly material, which is not only recyclable after use, but also consists of material produced from +95% recycled post consumer material from food packing waste.



KOMPAN Springs are made of high quality spring steel according to EN10270. The springs are cleaned by phosphating before they are painted with an epoxy primer and a polyester powder coating as top finish. The springs are fixed by unique anti pinch fittings for maximum safety and long lifetime.

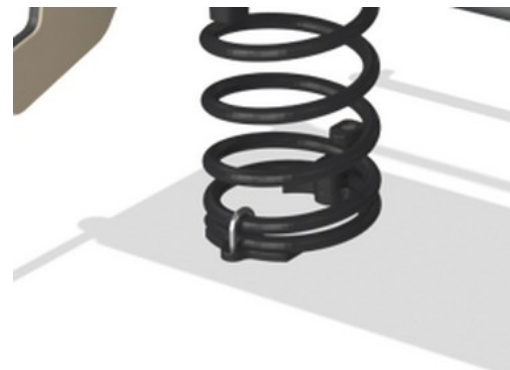

The springs are fixed by unique anti pinch fittings for maximum safety and long lifetime.



Handle is made of polypropylene PP with excellent impact strength and usable within a large temperature span.

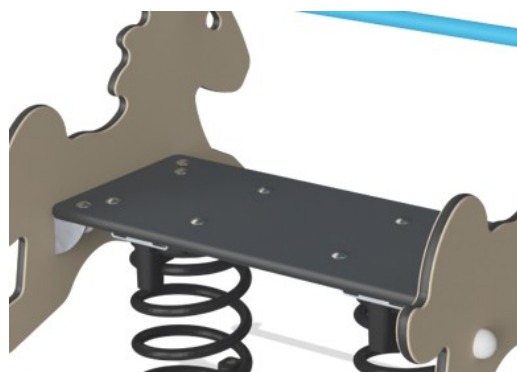

Seat is made of HPL with a thickness of 17.8mm with a very high wearing strength and a unique KOMPAN nonskid surface texture.

Item no. PCM106-0401	
Installation Information	
Max. fall height	40 cm
Safety surfacing area	17.7 m <sup>2</sup>
Total installation time	2.8
Excavation volume	0.27 m <sup>3</sup>
Concrete volume	0.00 m <sup>3</sup>
Footing depth (standard)	42 cm
Shipment weight	55 kg
Anchoring options	In-ground ✓ Surface ✓
Warranty Information	
EcoCore HDPE	Lifetime
Spare parts guaranteed	10 years
Springs	5 years

Elevated activities 0	Accessible elevated activities	Accessible ground level activities	Accessible ground level play types
Present	0	1	1
Required	0	1	1



# Sustainability Data

PCM106

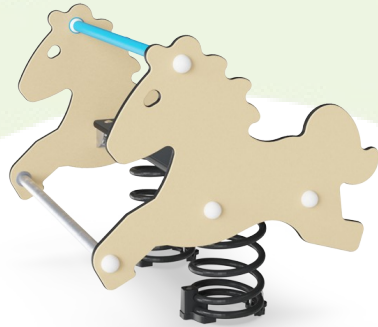

Cradle to Gate A1-A3	Total CO <sub>2</sub> emission	CO <sub>2</sub> e/kg	Recycled materials
	kg CO <sub>2</sub> e	kg CO <sub>2</sub> e/kg	%
<b>PCM106-0401</b>	121.09	2.32	40.61

The overall framework applied for these factors is the Environmental Product Declaration (EPD), which quantifies "environmental information on the life cycle of a product and enable comparisons between products fulfilling the same function" (ISO, 2006). This follows the structure and applies a Life-Cycle Assessment approach to the entire Product stage from raw material through manufacturing (A1-A3))

**Kompan A/S**  
 C.F. Tietgens Boulevard 32C  
 DK-5220 Odense SØ  
 Denmark



## Verification of CO<sub>2</sub> calculation of: Freestanding play equipment



Data version no. 2023-10-05

The CO<sub>2</sub> calculation and data are in compliance with the principles of a carbon footprint impact according to the GHG protocol (Greenhouse Gas Protocol), Scope 3, cradle to gate related to all individual components in the product category: "Freestanding play equipment" represented by item no.: GXY916012-3417.

(Scope 3 emissions include emission sources in the upstream and downstream value chain).

**Date: 30. October 2023 | Valid until: 30. October 2025**

**Verified by:**

Julie Marie Vejsgaard Larsen, LCA & EPD Consultant

Verification based on report: Validation of CO<sub>2</sub> calculation of 9 categories of Kompan product line, version 1.0, prepared by: Bureau Veritas HSE, Denmark: Julie M. V. Larsen.

**Publication date: 30. October 2023**

**By Bureau Veritas HSE**  
 www.bureauveritas.dk  
 +45 7731 1000



# Horse, Double

PCM106

\* Max fall height | \*\* Total height | \*\*\* Safety surfacing area

\* Max fall height | \*\* Total height

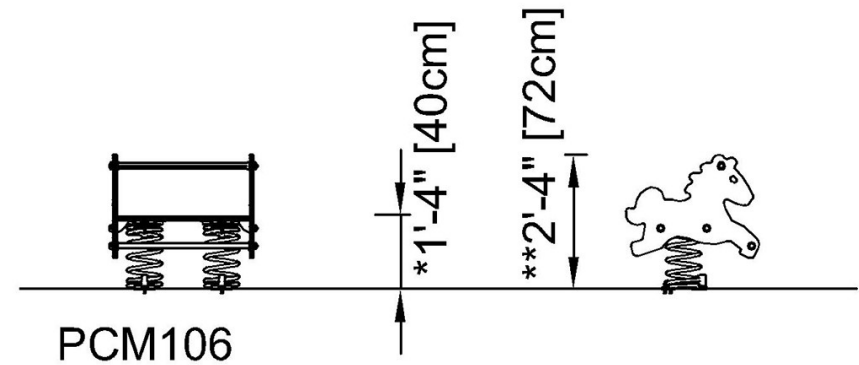
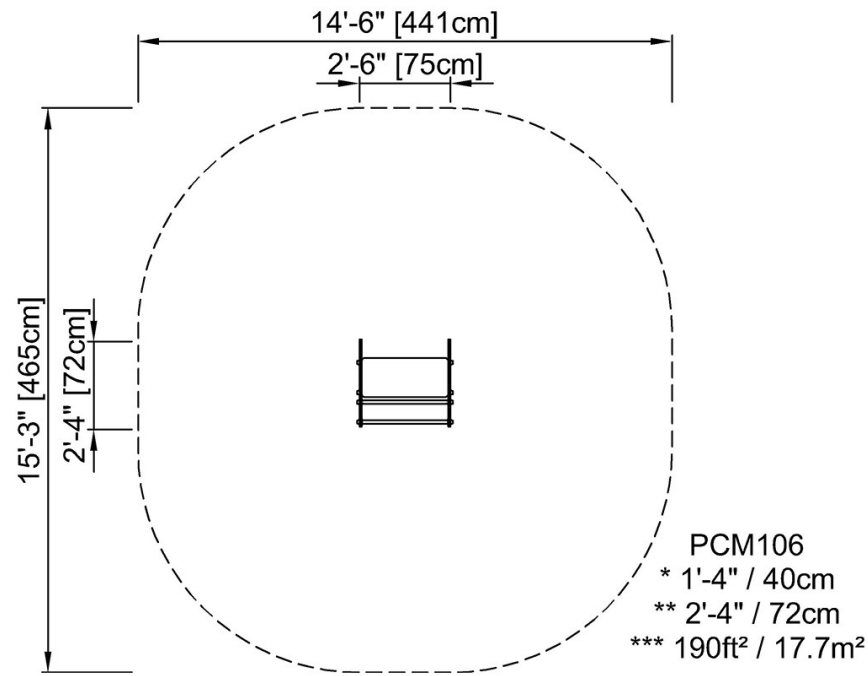

[Click to see TOP VIEW](#)

[Click to see SIDE VIEW](#)