

Little Duck's Gate

NRO416



Item no. NRO416-1021	
General Product Information	
Dimensions LxWxH	5'9"x9'4"x9'3"
Age group	2 - 5
Play capacity (users)	10
Color options	



The activity-packed, house-themed Little Duck's Gate will attract and excite toddlers again and again. Rich tactile features increase play value and support emerging dramatic play in toddlers. The scale of the house is perfectly sized for toddlers. The desk adds to the overall transparency so that children can play together from the outside and the inside of the house.

The side panel with yellow scoops that run in a groove encourages play that stimulates theory of mind and logical thinking skills. The leafy crawl-through panel encourages children to crawl and explore. These tactile activities stimulate cross-modal perception, important for improving reading skills and support cross-coordination awareness which is key to

physical and cognitive development at this age.



Little Duck's Gate

NRO416



Side desk

Social-Emotional: fine meeting place and a space creator. Sharing and cooperation from both sides create a social scenario that supports communication and cooperation.



Theme

Cognitive: suggests a theme and supports dramatic play, which stimulates language and communication skills.



Crawl-through hole

Physical: the hole allows for climbing and crawling through, developing cross coordination, proprioception and spatial awareness. **Social-Emotional:** cooperation and turn-taking when passing one another.



Sand scoops panel

Physical: hand eye coordination and push-pull movements. **Social-Emotional:** invites cooperation with two sides and provides for parallel play. **Cognitive:** logical thinking: cause and effect understanding when running scoops in grooves or shifting materials from scoop to scoop. **Creative:** shifting scoops, creating new scoop positions.

Little Duck's Gate

NRO416



All Organic Robinia products by KOMPAN are made of Robinia wood from sustainable European sources. On request it can be supplied as FSC® Certified (FSC® C004450).



The product/activities are preassembled from the factory to ensure all safety requirements are considered.



The paint used for colored components is water based environmental friendly with excellent UV resistance. The paint is in compliance with EN 71 Part 3.



Panels of 19mm EcoCore™. EcoCore™ is a highly durable, eco friendly material, which is not only recyclable after use, but also consists of a core produced from 100% recycled material.



There are Multiple footing options for all products: Surface anchoring with steel footings and expansion bolts. Wood in-ground or steel in-ground footings.



Robinia products are available in three different wood treatment options: untreated Robinia wood or brown painted with a pigment that maintains the wood color and colored version with paint of selected components.

Item no. NRO416-1021

Installation Information

Max. fall height	0'0"
Safety surfacing area	0ft ²
Total installation time	11.1
Excavation volume	0.82yd ³
Concrete volume	0yd ³
Footing depth (standard)	3'3"
Shipment weight	1116lbs
Anchoring options	In-ground ✓ Surface ✓

Warranty Information

EcoCore HDPE	Lifetime
Hot dip galvanized steel	Lifetime
Robinia Wood	10 Years
Spare Parts Availability	10 Years
Stainless steel components	Lifetime

Elevated activities 0	Accessible elevated activities	Accessible ground level activities	Accessible ground level play types
Present	0	3	3
Required	0	3	3

**ASTM
F1487**
compliant

Sustainability Data

NRO416



Cradle to Gate A1-A3	Total CO ₂ emission	CO ₂ e/kg	Recycled materials
	kg CO ₂ e	kg CO ₂ e/kg	%
NRO416-1021	103.05	0.23	3.53

The overall framework applied for these factors is the Environmental Product Declaration (EPD), which quantifies "environmental information on the life cycle of a product and enable comparisons between products fulfilling the same function" (ISO, 2006). This follows the structure and applies a Life-Cycle Assessment approach to the entire Product stage from raw material through manufacturing (A1-A3))

Kompan A/S
 C.F. Tietgens Boulevard 32C
 DK-5220 Odense SØ
 Denmark



Verification of CO₂ calculation of: Nature play



Data version no. 2023-10-05

The CO₂ calculation and data are in compliance with the principles of a carbon footprint impact according to the GHG protocol (Greenhouse Gas Protocol), Scope 3, cradle to gate related to all individual components in the product category: "Nature play" represented by item no.: NRO409-0621.

(Scope 3 emissions include emission sources in the upstream and downstream value chain).

Date: 30. October 2023 | Valid until: 30. October 2025

Verified by:

Julie Marie Vejsgaard Larsen, LCA & EPD Consultant

Verification based on report: Validation of CO₂ calculation of 9 categories of Kompan product line, version 1.0, prepared by: Bureau Veritas HSE, Denmark: Julie M. V. Larsen.

Publication date: 30. October 2023

By Bureau Veritas HSE
 www.bureauveritas.dk
 +45 7731 1000



Little Duck's Gate

NRO416

* Max fall height | ** Total height | *** Safety surfacing area

* Max fall height | ** Total height

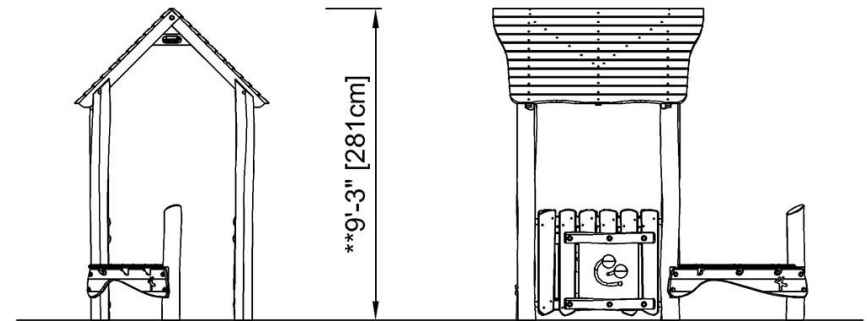
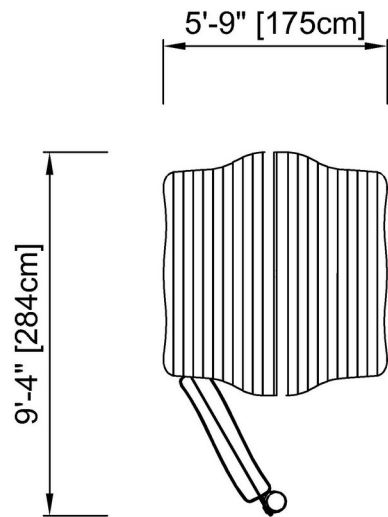

NRO416

NRO416
** 9'-3" / 281cm

[Click to see TOP VIEW](#)

[Click to see SIDE VIEW](#)