

Fiskekutter og butik

PCM52531

KOMPANI
Let's play



Varenr. PCM52531-0901

Generel produktinformation

Dimensioner LxBxH	342x352x311 cm
Alder	2+
Antal brugere	13
Farvemuligheder	●



The countless play activities of the Cutter and Fish Shop play unit inspire children to play and imagine together, for long, again and again. The many explorative play features such as play panels with sounding gearing wheels, climb-through dense and the funnel leading to the treasure box all inspire countless dramatic play scenarios while stimulating them to

explore the many tactile, moving play features. The explorative and creative play from the wheels play panel intrigues children's creativity and builds their understanding of cause and effect. Often they spur make-believe play such as shop or cutter. This makes children play together, learn turn-taking and empathy and make friends.



Fiskekutter og butik

PCM52531



Spand og rør

Social-emotionelle evner: invites cooperation due to the two-sidedness.
Kognitive evner: når materialerne passerer gennem tragte, understøtter det børnenes logiske tænkning og for yngre børn forståelsen af objektpermanens: at materialer ikke forsvinder, men løber igennem i den anden ende. **Kreative evner:** children can leave their mark, placing the membranes in different positions.



Tema

Kognitive evner: er tematisk og understøtter rolleleg, som stimulerer sprog- og kommunikationsevner.



Reb med gummiskive

Fysiske evner: børn udvikler krydskoordinering og muskelstyrke når de klatrer og træder på skiven. Samtidig trænes balancesansen som bl.a. er vigtig for at kunne sidde stille. **Social-emotionelle evner:** understøtter sociale færdigheder og tage skift.



"Kravle-igennem" panel med gardiner

Fysiske evner: her udvikles krydskoordinering, rumlig bevidsthed og den proprioceptive sans, som børn klatrer og kravler igennem. **Social-emotionelle evner:** her understøttes samarbejde og tage skift, som børn leger med deres venner. **Kognitive evner:** understøtter forståelsen af objektets varighed: at ting kan stadig eksistere selvom de er ude af syne.

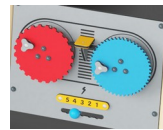

Lydpanel

Fysiske evner: turning the wheels require big hand and arm movements. This develops dexterity, hand and arm muscles. **Social-emotionelle evner:** individual and social play: cooperation and co-creation when making specific sounds. **Kognitive evner:** cause and effect understanding as well as make-believe play. Creating sounds and rhythms trains essential pre-reading skills. **Kreative evner:** creating varied sounds and rhythms.



Gearhjul

Social-emotionelle evner: her tilskyndes børn til samarbejde og tage skift, som de drejer gearhjulet. **Kognitive evner:** understøtter logisk tænkning og forståelsen af årsag og virkning.



Rat

Kognitive evner: det manipulerende rat inviterer til dramatisk leg, der understøtter sprog- og kommunikationsevner.

Fiskekutter og butik

PCM52531



Paneler af 19 mm EcoCore™. EcoCore™ er et meget holdbart materiale, som ikke kun kan genbruges efter brug, men som også består af materiale, der er produceret af +95 % genanvendt materiale fra fødevareemballageaffald.



Main posts with hot dip galvanized steel footing are available in different materials: Pre-galvanized inside and outside with powder coated top finish steel posts. Lead free aluminum with color anodized top finish. TexMade posts of 95% post-consumer recycled PE and textile waste.



Ståloverfladerne er varmgalvaniseret indvendigt og udvendigt med blyfri zink. Galvaniseringen har fremragende korrosionsbestandighed i udendørs miljøer og kræver lav vedligeholdelse.



KOMPAN GreenLine-versioner er designet med ultimative holdbare materialer med den lavest mulige CO2e-udledningsfaktor. TexMade-stolpe, EcoCore™-paneler af 95 % genanvendt forbrugsaffald og støbte PP-platfomer.

Varenr. PCM52531-0901

Installationsinformation

Maks. faldhøjde	40 cm
Faldområde	28,4 m ²
Installationstid (timer)	23,8
Udgravningsmængde	0,43 m ³
Betonmængde	0,00 m ³
Forankringsdybde	90 cm
Fragtvægt	733 kg
Forankringsmuligheder	Overflade ✓ I jorden ✓

Garanti

EcoCore HDPE	Livstid
Galvaniseret stål	Livstid
Bevægelige dele	2 år
Stolpe	10 år
Garanterede reservedele	10 år

Bæredygtighedsdata

PCM52531



Vugge-til-port A1-A3	Total CO ₂ udledning	CO ₂ e/kg	Gen-anvendte materialer
	kg CO ₂ e	kg CO ₂ e/kg	%
PCM52531-0901	694,10	1,37	78,85

Den overordnede ramme for disse faktorer er Environmental Product Declaration (EPD), som kvantificerer "miljøoplysninger om et produkts livscyklus og muliggør sammenligninger mellem produkter, der opfylder samme funktion" (ISO, 2006). Dette følger strukturen og anvender en livscyklusvurderingstilgang til hele produktfasen fra råvarer til fremstilling (A1-A3))

Kompan A/S
C.F. Tietgens Boulevard 32C
DK-5220 Odense SØ
Denmark



Verification of CO₂ calculation of: Play systems



Data version no. 2023-10-05

The CO₂ calculation and data are in compliance with the principles of a carbon footprint impact according to the GHG protocol (Greenhouse Gas Protocol), Scope 3, cradle to gate related to all individual components in the product category: "Play systems" represented by item no.: PCM200321-0950.

(Scope 3 emissions include emission sources in the upstream and downstream value chain).

Date: 30. October 2023 | Valid until: 30. October 2025

Verified by:

Julie Marie Vejsgaard Larsen, LCA & EPD Consultant

Verification based on report: Validation of CO₂ calculation of 9 categories of Kompan product line, version 1.0, prepared by: Bureau Veritas HSE, Denmark: Julie M. V. Larsen.

Publication date: 30. October 2023

By Bureau Veritas HSE
www.bureauveritas.dk
+45 7731 1000



Fiskekutter og butik

PCM52531

* Maks. faldhøjde | ** Samlet højde | *** Faldområde

* Maks. faldhøjde | ** Samlet højde

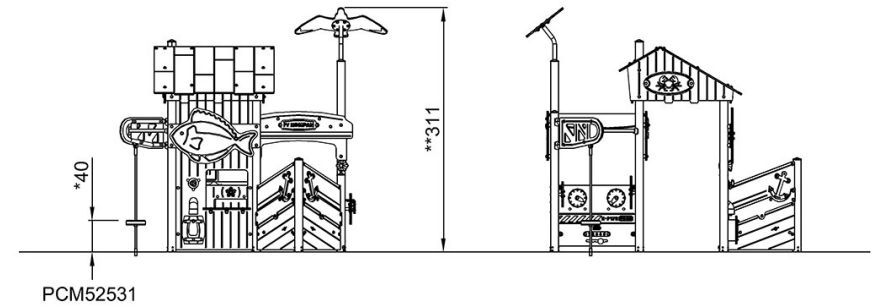
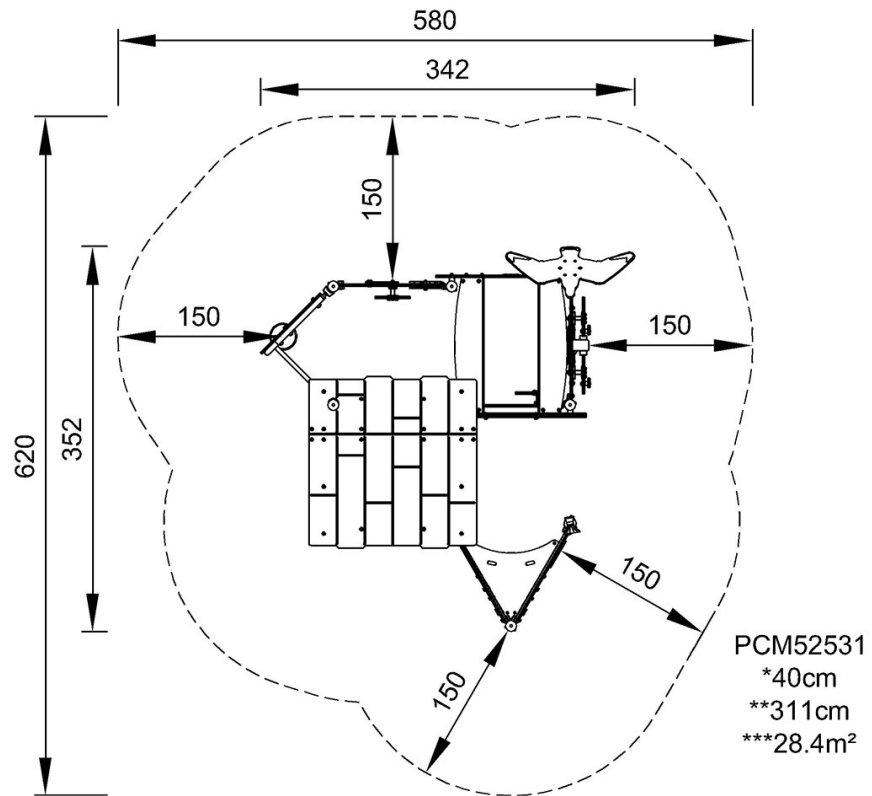

[Klik for at se FRA OVEN](#)

[Klik for at se FRA SIDEN](#)