

Sandworks

PCM103931



Item no. PCM103931-0903	
General Product Information	
Dimensions LxWxH	254x243x217 cm
Age group	2+
Play capacity (users)	10
Colour options	



The Sandworks is an immensely attractive sand play unit that will absorb children in play for hours and hours. The crane is worked by pulling the chain. The sand bucket will go up or down or all around, but it will stay put when the chain is let go of. This, apart from providing fascinating sand play, is a great training of children's logical thinking skills. The negotiation

and cooperation to get sand to and from the sand table develops social-emotional skills. The sand table's sieve and tube lead sand away, training young children's understanding of object permanence: that things can still exist when out of sight. The sand bucket and shovel adds a quieter sand play corner. The platform is open and can be accessed in multiple ways,

allowing for all users to play.



Sandworks

PCM103931



Funnel

Social-Emotional: trains cooperation and turn-taking as children put materials into the funnel. **Cognitive:** the passing of materials through funnels supports the children's logical thinking and for younger children the understanding of object permanence: that materials don't vanish but run through at the other end.



Desk

Social-Emotional: fine meeting place and a space creator. Sharing and cooperation from both sides create a social scenario that supports communication and cooperation.



Sand bucket

Physical: cross coordination thereby developing cooperation of left and right brain half which is necessary for academic skills such as reading. **Cognitive:** understanding of object permanence, emptying and filling bucket.



Sand hoist

Physical: pulling the chain trains hand and arm muscles as well as the coordination. **Social-Emotional:** cooperation and turn-taking skills are supported when cooperating on filling and hoisting sand up and down. **Cognitive:** logical thinking skills are trained when understanding that pulling down makes the sand shovel go up. **Creative:** working with moveable play items supports the child's creativity.



Sand shovel

Physical: develops dexterity and upper body muscles. **Cognitive:** understanding of object permanence, emptying and filling scoop.

Sandworks

PCM103931



Panels of 19mm EcoCore™. EcoCore™ is a highly durable, eco friendly material, which is not only recyclable after use, but also consists of material produced from +95% recycled post consumer material from food packing waste.



Main posts with hot dip galvanized steel footing are available in different materials: Pressure impregnated pine wood posts. Pre-galvanized inside and outside with powder coated top finish steel posts. Lead free aluminum with color anodized top finish. Greenline TexMade posts of 95% post-consumer recycled PE and textile waste.



All decks are supported by unique designed low-carbon aluminum profiles with multiple attachment options. The grey colored molded decks are made of 75% post-consumer waste PP material with a non-skid pattern and texture surface.

Item no. PCM103931-0903

Installation Information

Max. fall height	48 cm
Safety surfacing area	22.2 m ²
Total installation time	10.4
Excavation volume	0.25 m ³
Concrete volume	0.01 m ³
Footing depth (standard)	90 cm
Shipment weight	264 kg
Anchoring options	In-ground ✓ Surface ✓

Warranty Information

EcoCore HDPE	Lifetime
Post	10 years
PP Decks	10 years
Solid plastic parts	10 years
Spare parts guaranteed	10 years

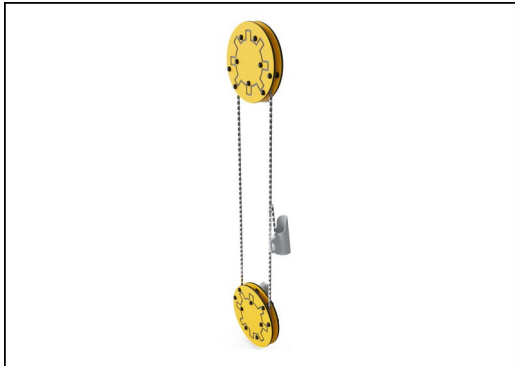

The sand hoist is designed with upper and lower EcoCore tracks of large diameter that always ensures safe distance between the chains so they can't be crossed for entanglement. The chain is made of high-quality stainless-steel to ensure long durability of the product.



The sand bucket is made in one piece of molded PE. The PE is made with 33% post-consumer materials in different colors with a wall thickness of minimum 5mm. Material in accordance with the European Standard EN 71-3 and tested for UV stability.



KOMPAN GreenLine versions are designed with ultimate environmentally friendly materials with lowest possible CO2e emission factor. TexMade post, EcoCore™ panels of 95% post-consumer recycled waste and molded PP decks.



Sustainability Data

PCM103931



Cradle to Gate A1-A3	Total CO ₂ emission	CO ₂ e/kg	Recycled materials
	kg CO ₂ e	kg CO ₂ e/kg	%
PCM103931-0950	474.53	2.30	60.68
PCM103931-0903	528.50	2.82	50.77

The overall framework applied for these factors is the Environmental Product Declaration (EPD), which quantifies "environmental information on the life cycle of a product and enable comparisons between products fulfilling the same function" (ISO, 2006). This follows the structure and applies a Life-Cycle Assessment approach to the entire Product stage from raw material through manufacturing (A1-A3))

Kompan A/S
C.F. Tietgens Boulevard 32C
DK-5220 Odense SØ
Denmark



Verification of CO₂ calculation of: Play systems



Data version no. 2023-10-05

The CO₂ calculation and data are in compliance with the principles of a carbon footprint impact according to the GHG protocol (Greenhouse Gas Protocol), Scope 3, cradle to gate related to all individual components in the product category: "Play systems" represented by item no.: PCM200321-0950.

(Scope 3 emissions include emission sources in the upstream and downstream value chain).

Date: 30. October 2023 | Valid until: 30. October 2025

Verified by:

Julie Marie Vejsgaard Larsen, LCA & EPD Consultant

Verification based on report: Validation of CO₂ calculation of 9 categories of Kompan product line, version 1.0, prepared by: Bureau Veritas HSE, Denmark: Julie M. V. Larsen.

Publication date: 30. October 2023

By Bureau Veritas HSE
www.bureauveritas.dk
+45 7731 1000



* Max fall height | ** Total height | *** Safety surfacing area

* Max fall height | ** Total height

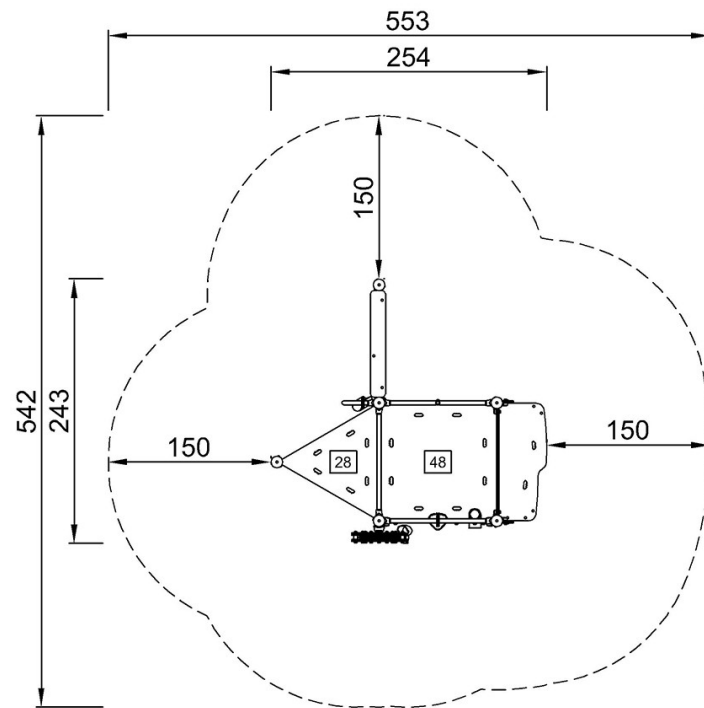

PCM103931
*48cm
**217cm
***22.2m²

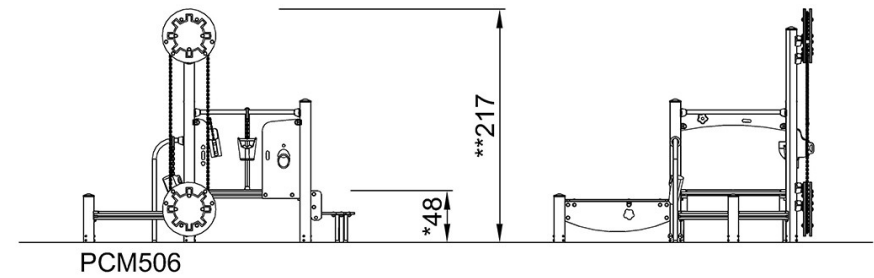

[Click to see TOP VIEW](#)

[Click to see SIDE VIEW](#)