

Spring Board

NRO104



Item no. NRO104-0402

General Product Information

Dimensions LxWxH	92x85x46 cm
Age group	3+
Play capacity (users)	3
Color options	 



The Spring Board is a lovely, inviting platform for rocking. Children will be attracted to it again and again, thanks to its fun, rocking movement and, not least, social potential: the platform allows more body positions. Lying, sitting, standing, even jumping. All have a chance to play together, in equal and unequal numbers. The social potential in that is immense.

Children will cooperate, turn-take and show consideration on others to make the fun, rocking movement of the Spring Board continue. The rocking movement trains the senses of balance and space. These are both crucial for body confidence, e.g. in avoiding falling. A well-developed sense of balance is fundamental for the ability to sit still and

concentrate. When standing on the platform, children will jump, building bone density for life when doing so, having fun.



Data is subject to change without prior notice.

Spring Board

NRO104



All Organic Robinia products by KOMPAN are made of Robinia wood from sustainable European sources. On request it can be supplied as FSC® Certified (FSC® C004450).



KOMPAN Springs are made of high quality spring steel according to EN10270. The springs are cleaned by phosphating before they are painted with an epoxy primer and a polyester powder coating as top finish. The springs are fixed by unique anti pinch fittings for maximum safety and long lifetime.



The Robinia wood can be supplied as untreated raw wood or painted with a brown coloured transparent pigment that maintains the golden wood colour of the wood.

Item no. NRO104-0402	
Installation Information	
Max. fall height	60 cm
Safety surfacing area	11.6 m ²
Total installation time	2.9
Excavation volume	0.77 m ³
Concrete volume	0.00 m ³
Footing depth (standard)	45 cm
Shipment weight	135 kg
Anchoring options	In-ground ✓ Surface ✓



Sustainability Data

NRO104



Cradle to Gate A1-A3	Total CO ₂ emission	CO ₂ e/kg	Recycled materials
	kg CO ₂ e	kg CO ₂ e/kg	%
NRO104-0402	163.70	1.46	24.50

The overall framework applied for these factors is the Environmental Product Declaration (EPD), which quantifies "environmental information on the life cycle of a product and enable comparisons between products fulfilling the same function" (ISO, 2006). This follows the structure and applies a Life-Cycle Assessment approach to the entire Product stage from raw material through manufacturing (A1-A3))

Kompan A/S
C.F. Tietgens Boulevard 32C
DK-5220 Odense SØ
Denmark



Verification of CO₂ calculation of: Nature play



Data version no. 2023-10-05

The CO₂ calculation and data are in compliance with the principles of a carbon footprint impact according to the GHG protocol (Greenhouse Gas Protocol), Scope 3, cradle to gate related to all individual components in the product category: "Nature play" represented by item no.: NRO409-0621.

(Scope 3 emissions include emission sources in the upstream and downstream value chain).

Date: 30. October 2023 | Valid until: 30. October 2025

Verified by:

Julie Marie Vejsgaard Larsen, LCA & EPD Consultant

Verification based on report: Validation of CO₂ calculation of 9 categories of Kompan product line, version 1.0, prepared by: Bureau Veritas HSE, Denmark: Julie M. V. Larsen.

Publication date: 30. October 2023

By Bureau Veritas HSE
www.bureauveritas.dk
+45 7731 1000



Spring Board

NRO104

* Max fall height | ** Total height | *** Safety surfacing area

* Max fall height | ** Total height

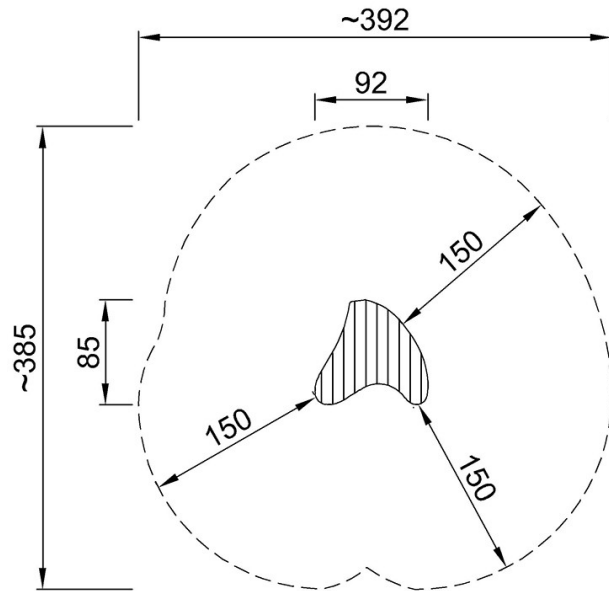

NRO104
*60cm
**46cm
***11.6m²



[Click to see TOP VIEW](#)

[Click to see SIDE VIEW](#)