

Double Tower with Bridge

PCM200231

KOMPAN
Let's play

Item no. PCM200231-0902

General Product Information

Dimensions LxWxH	596x165x221 cm
Age group	2 - 5
Play capacity (users)	11
Colour options	

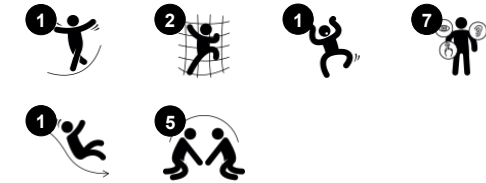

This fantastic double play tower has lots of play activities for all. This will encourage children to play together and will enrich their physical development. The varied entry points train muscles and cross-coordination. On the elevated level, the sloping bridge trains the sense of balance and space, thrilling for young children. The playhouse is a fine gathering

point, and the slide invites social play. Sliding supports posture and balance, all important skills for young children. On ground level, the desk under the play tower encourages socialising and adds a rest point before venturing onto the next play experience.

Double Tower with Bridge

PCM200231



Theme

Cognitive: suggests a theme and supports dramatic play, which stimulates language and communication skills.



Window

Social-Emotional: invites interaction between sides and cooperative play.



Slide

Physical: sliding develops spatial awareness and a sense of balance. Furthermore, the core muscles are trained when sitting upright going down. **Social-Emotional:** empathy stimulated by turn-taking. **Cognitive:** young children develop their understanding of space, speed and distances when sliding down quickly.



Desk

Social-Emotional: fine meeting place and a space creator. Sharing and cooperation from both sides create a social scenario that supports communication and cooperation.



Bridge

Physical: cross coordination, spatial awareness. **Social-Emotional:** transparency invite cooperation with children on the outside.

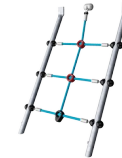

Climbing net

Physical: supports physical strength and cross-body coordination, which impacts coordination of the right and left part of brain, fundamental for other skills such as the ability to read.



Accessible stairway

Physical: climbing the accessible stairway is for all and supports cross coordination as well as arm and leg muscles. For young children, walking stairs and alternating feet is developed. **Social-Emotional:** room for active breaks and adult helpers. An inclusive space.

Double Tower with Bridge

PCM200231



Panels of 19mm EcoCore™. EcoCore™ is a highly durable, eco friendly material, which is not only recyclable after use, but also consists of material produced from +95% recycled post consumer material from food packing waste.



Main posts with hot dip galvanized steel footing are available in different materials: Pressure impregnated pine wood posts. Pre-galvanized inside and outside with powder coated top finish steel posts. Lead free aluminum with color anodized top finish. Greenline TexMade posts of 95% post-consumer recycled PE and textile waste.



All decks are supported by unique designed low-carbon aluminum profiles with multiple attachment options. The grey colored molded decks are made of 75% post-consumer waste PP material with a non-skid pattern and texture surface.



The slides can be chosen in six different colors and three materials: Straight or curved one-piece molded PE slides, made from 33% recycled post-consumer materials in different colours. Combined EcoCore™ sides and stainless-steel. Full stainless steel in one piece design for more vandalism proof solutions.



Ropes of UV-stabilized PES rope strands with inner steel cable reinforcement. The polyester yarn is made from +95% post-consumer materials and is inductively melted onto each strand.



KOMPAN GreenLine versions are designed with ultimate environmentally friendly materials with lowest possible CO2e emission factor. TexMade post, EcoCore™ panels of 95% post-consumer recycled waste and molded PP decks.

Item no. PCM200231-0902

Installation Information

Max. fall height	174 cm
Safety surfacing area	42.0 m ²
Total installation time	19.1
Excavation volume	0.69 m ³
Concrete volume	0.00 m ³
Footing depth (standard)	90 cm
Shipment weight	587 kg
Anchoring options	In-ground <input checked="" type="checkbox"/> Surface <input checked="" type="checkbox"/>

Warranty Information

EcoCore HDPE	Lifetime
Post	10 years
PP Decks	10 years
Ropes & nets	10 years
Spare parts guaranteed	10 years

Elevated activities 3	Accessible elevated activities	Accessible ground level activities	Accessible ground level play types
Present	3	1	1
Required	2	1	1

**CSA
Z614**
compliant

Sustainability Data

PCM200231



Cradle to Gate A1-A3	Total CO ₂ emission	CO ₂ e/kg	Recycled materials
	kg CO ₂ e	kg CO ₂ e/kg	%
PCM200231-0951	632.37	1.36	75.56
PCM200231-0902	856.92	2.05	63.75

The overall framework applied for these factors is the Environmental Product Declaration (EPD), which quantifies "environmental information on the life cycle of a product and enable comparisons between products fulfilling the same function" (ISO, 2006). This follows the structure and applies a Life-Cycle Assessment approach to the entire Product stage from raw material through manufacturing (A1-A3))

Kompan A/S
 C.F. Tietgens Boulevard 32C
 DK-5220 Odense SØ
 Denmark



Verification of CO₂ calculation of: Play systems



Data version no. 2023-10-05

The CO₂ calculation and data are in compliance with the principles of a carbon footprint impact according to the GHG protocol (Greenhouse Gas Protocol), Scope 3, cradle to gate related to all individual components in the product category: "Play systems" represented by item no.: PCM200321-0950.

(Scope 3 emissions include emission sources in the upstream and downstream value chain).

Date: 30. October 2023 | Valid until: 30. October 2025

Verified by:

Julie Marie Vejsgaard Larsen, LCA & EPD Consultant

Verification based on report: Validation of CO₂ calculation of 9 categories of Kompan product line, version 1.0, prepared by: Bureau Veritas HSE, Denmark: Julie M. V. Larsen.

Publication date: 30. October 2023

By Bureau Veritas HSE
 www.bureauveritas.dk
 +45 7731 1000



Double Tower with Bridge

PCM200231

* Max fall height | ** Total height | *** Safety surfacing area

* Max fall height | ** Total height

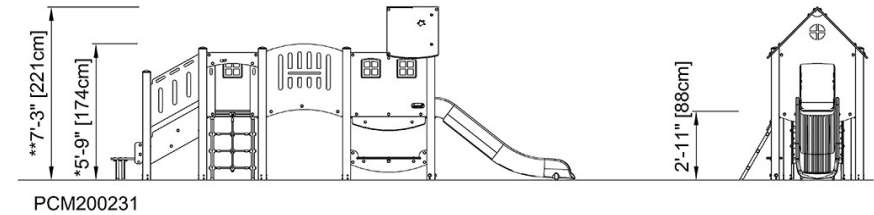
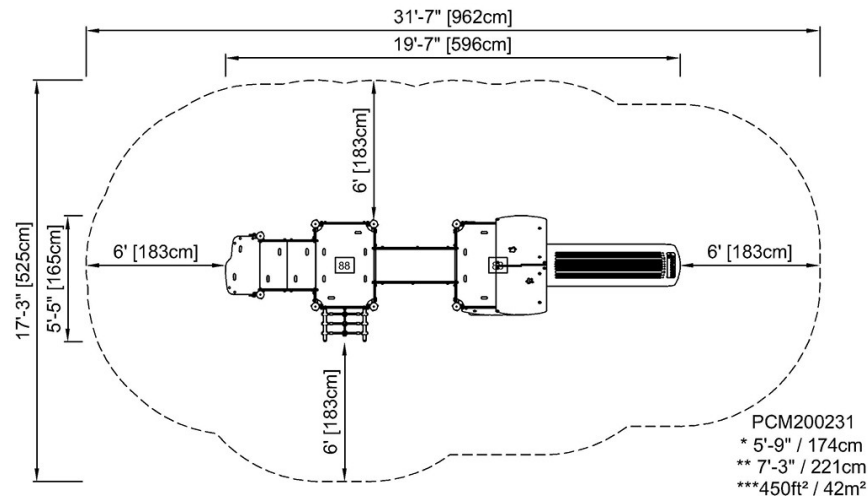

[Click to see TOP VIEW](#)

[Click to see SIDE VIEW](#)