

Petrol Station with 2 Pumps

NRO513



This petrol station with two pumps is great for any tricycle track. It will appeal to role play around the themes of driving and traffic, which is always a great imaginative support for the child. This will add attraction and play time. The petrol station is made in rope, and the handle as this will appeal to role play around the themes of driving and traffic. These are hugely

popular and will attract children for hours of dramatic play, again and again. The pumps are elaborate with rubber tube and the red, green and yellow buttons for choosing the right octane strength. All in all the variety of materials stimulates the fine motor skills and tactile sense, especially for the youngest players. The dramatic play around traffic and

gas stations stimulates the child's language development in evoking storytelling and imagination.

Item no. NRO513-1021	
General Product Information	
Dimensions LxWxH	200x81x221 cm
Age group	2+
Play capacity (users)	2
Colour options	



Petrol Station with 2 Pumps

NRO513



Theme

Cognitive: suggests a theme and supports dramatic play, which stimulates language and communication skills.



Two pumps

Social-Emotional: the two pumps invite cooperation and co-creation, on both sides and between the two sides. The transparency makes interaction possible between the two sides.



Fuel handle

Social-Emotional: cooperation skills and turn-taking are supported when fueling vehicles for friends. **Cognitive:** dramatic play stimulates language development.

Petrol Station with 2 Pumps

NRO513



All Organic Robinia products by KOMPAN are made of Robinia wood from sustainable European sources. On request it can be supplied as FSC® Certified (FSC® C004450).



The paint used for coloured components is water based environmentally friendly with excellent UV resistance. The paint is in compliance with EN 71 Part 3.



Ropes are made of UV-stabilised PA with inner steel cable reinforcement. The rope is induction treated in order to create a strong connection between steel and rope which leads to good wear resistance.



Robinia products are available in three different wood treatment options: Untreated Robinia wood or brown painted with a pigment that maintains the wood colour and coloured version with paint of selected components.

Item no. NRO513-1021	
Installation Information	
Max. fall height	0 cm
Safety surfacing area	10.1 m ²
Total installation time	4.2
Excavation volume	0.40 m ³
Concrete volume	0.00 m ³
Footing depth (standard)	100 cm
Shipment weight	273 kg
Anchoring options	In-ground ✓
Warranty Information	
Robinia wood	15 years
Spare parts guaranteed	10 years
Stainless steel components	Lifetime



Sustainability Data

NRO513



Cradle to Gate A1-A3	Total CO ₂ emission	CO ₂ e/kg	Recycled materials
	kg CO ₂ e	kg CO ₂ e/kg	%
NRO513-1021	43.90	0.20	1.32

The overall framework applied for these factors is the Environmental Product Declaration (EPD), which quantifies "environmental information on the life cycle of a product and enable comparisons between products fulfilling the same function" (ISO, 2006). This follows the structure and applies a Life-Cycle Assessment approach to the entire Product stage from raw material through manufacturing (A1-A3))

Kompan A/S
C.F. Tietgens Boulevard 32C
DK-5220 Odense SØ
Denmark



Verification of CO₂ calculation of: Nature play



Data version no. 2023-10-05

The CO₂ calculation and data are in compliance with the principles of a carbon footprint impact according to the GHG protocol (Greenhouse Gas Protocol), Scope 3, cradle to gate related to all individual components in the product category: "Nature play" represented by item no.: NRO409-0621.

(Scope 3 emissions include emission sources in the upstream and downstream value chain).

Date: 30. October 2023 | Valid until: 30. October 2025

Verified by:

Julie Marie Vejsgaard Larsen, LCA & EPD Consultant

Verification based on report: Validation of CO₂ calculation of 9 categories of Kompan product line, version 1.0, prepared by: Bureau Veritas HSE, Denmark: Julie M. V. Larsen.

Publication date: 30. October 2023

By Bureau Veritas HSE
www.bureauveritas.dk
+45 7731 1000



Petrol Station with 2 Pumps

NRO513

* Max fall height | ** Total height | *** Safety surfacing area

* Max fall height | ** Total height

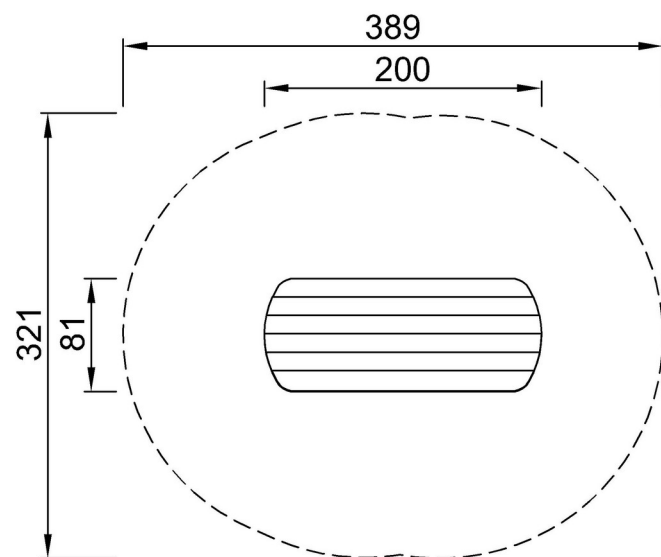

NRO513
**221cm
***10.1m²

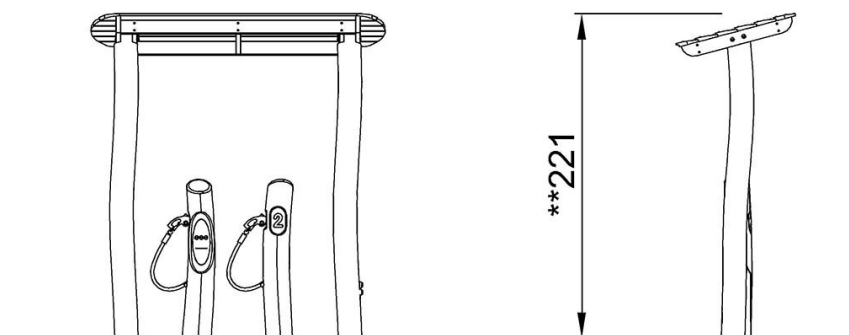

NRO513

[Click to see TOP VIEW](#)

[Click to see SIDE VIEW](#)