

Large Slide Tower

PCM114721

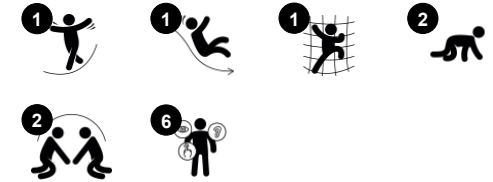

Item no. PCM114721-0901	
General Product Information	
Dimensions LxWxH	401x121x410 cm
Age group	4+
Play capacity (users)	4
Colour options	



The large tower with a tall and thrilling slide, will attract children to play actively again and again. The pipe ladder offers a challenging way up, training arms and leg muscles, as well as cross-coordination. Cross-coordination enhances children's ability to use both sides of the brain, supporting the internal structures enabling reading and thinking. The slide is

great fun, training children's sense of balance, spatial awareness and core muscles when sitting upright going down. On the slide as well as the pipe ladder, children learn about turn-taking, empathy, and cooperation. These are important socio-emotional skills for corporative play. The platform provides a place to be together with friends.

Large Slide Tower

PCM114721



Slide

Physical: sliding develops spatial awareness and a sense of balance. Furthermore, the core muscles are trained when sitting upright going down. **Social-Emotional:** empathy stimulated by turn-taking.



Pipe ladder

Physical: cross coordination and eye-hand coordination are supported when children climb the ladder. The climbing also supports leg and arm muscles. **Social-Emotional:** learning about turn taking and cooperation.

Large Slide Tower

PCM114721



Panels of 19mm EcoCore™. EcoCore™ is a highly durable, eco friendly material, which is not only recyclable after use, but also consists of material produced from +95% recycled post consumer material from food packing waste.



Main posts with hot dip galvanized steel footing are available in different materials: Pressure impregnated pine wood posts. Pre-galvanized inside and outside with powder coated top finish steel posts. Lead free aluminum with color anodized top finish. Greenline TexMade posts of 95% post-consumer recycled PE and textile waste.



All decks are supported by unique designed low-carbon aluminum profiles with multiple attachment options. The grey colored molded decks are made of 75% post-consumer waste PP material with a non-skid pattern and texture surface.

Item no. PCM114721-0901	
Installation Information	
Max. fall height	178 cm
Safety surfacing area	27.2 m ²
Total installation time	8.5
Excavation volume	0.27 m ³
Concrete volume	0.00 m ³
Footing depth (standard)	90 cm
Shipment weight	337 kg
Anchoring options	In-ground ✓ Surface ✓
Warranty Information	
EcoCore HDPE	Lifetime
Hot dip galvanised steel	Lifetime
Post	10 years
PP Decks	10 years
Spare parts guaranteed	10 years

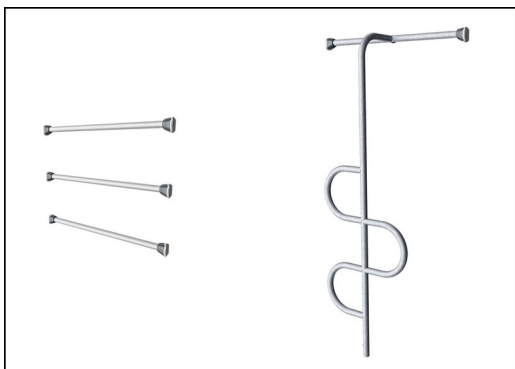

Pipe ladder bars are hot dip galvanised inside and outside with lead free zinc. The galvanisation has excellent corrosion resistance in outside environments and requires low maintenance.



The slides can be chosen in six different colours and three materials: Straight or curved one-piece molded PE slides; Combined EcoCore™ and stainless-steel slides; Full stainless steel in one-piece design for a more vandalism proof solution.



KOMPAN GreenLine versions are designed with ultimate environmentally friendly materials with lowest possible CO2e emission factor. TexMade post, EcoCore™ panels of 95% post-consumer recycled waste and molded PP decks.



Sustainability Data

PCM114721



Cradle to Gate A1-A3	Total CO ₂ emission	CO ₂ e/kg	Recycled materials
	kg CO ₂ e	kg CO ₂ e/kg	%
PCM114721-0950	367.71	1.29	75.66
PCM114721-0901	563.32	2.37	57.30

The overall framework applied for these factors is the Environmental Product Declaration (EPD), which quantifies "environmental information on the life cycle of a product and enable comparisons between products fulfilling the same function" (ISO, 2006). This follows the structure and applies a Life-Cycle Assessment approach to the entire Product stage from raw material through manufacturing (A1-A3))

Kompan A/S
C.F. Tietgens Boulevard 32C
DK-5220 Odense SØ
Denmark



Verification of CO₂ calculation of: Play systems



Data version no. 2023-10-05

The CO₂ calculation and data are in compliance with the principles of a carbon footprint impact according to the GHG protocol (Greenhouse Gas Protocol), Scope 3, cradle to gate related to all individual components in the product category: "Play systems" represented by item no.: PCM200321-0950.

(Scope 3 emissions include emission sources in the upstream and downstream value chain).

Date: 30. October 2023 | Valid until: 30. October 2025

Verified by:

Julie Marie Vejsgaard Larsen, LCA & EPD Consultant

Verification based on report: Validation of CO₂ calculation of 9 categories of Kompan product line, version 1.0, prepared by: Bureau Veritas HSE, Denmark: Julie M. V. Larsen.

Publication date: 30. October 2023

By Bureau Veritas HSE
www.bureauveritas.dk
+45 7731 1000



Large Slide Tower

PCM114721

* Max fall height | ** Total height | *** Safety surfacing area

* Max fall height | ** Total height

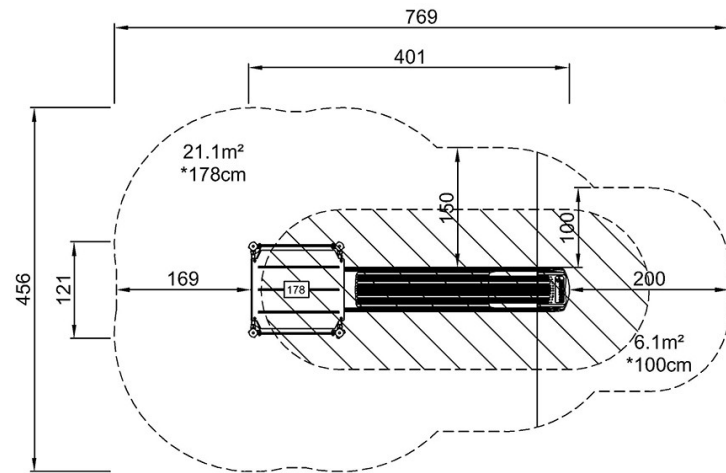

PCM114721
*178cm
**410cm
***27.2m²

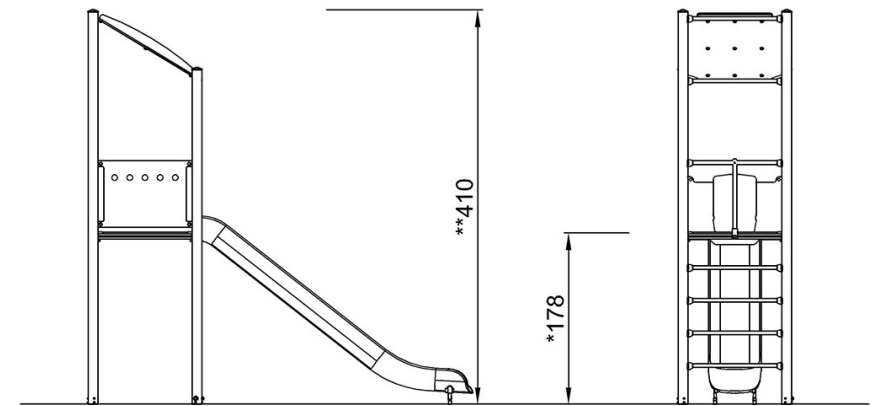

PCM114721

[Click to see TOP VIEW](#)

[Click to see SIDE VIEW](#)