

Shoulder Press

FSW40300

KOMPAN®



품번 FSW40300-0001

일반 제품 정보

크기 (가로 × 세로 × 높이)	125x157x123 cm
이용 연령	13+
수용 인원	1
색상 옵션	●



Featuring an adjustable load, the Shoulder Press provides authentic weight training for the shoulder and triceps muscles. The user-friendly handles with multi-function grips allow for various exercise positions and perfect ergonomics for users of all heights. The Shoulder Press is built for safety, with all mechanical stops enclosed within the cover to

ensure there are no crush points.



Shoulder Press

FSW40300

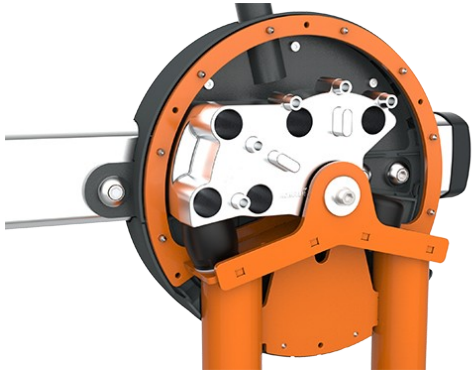

All mechanical stops are fully enclosed within the cover. The adjustable weight, featuring internal end stops and indexed positions, moves on rollers within an enclosed groove in an aluminium profile. As a result, entrapment is not possible, making it extremely safe to use and providing protection against the elements and unwanted abuse.



The weight on each side can be adjusted in 8 steps of 2,5 kg, providing a training weight from 5 to 40kg. The patent pending system is intuitive to use, eliminating the need for traditional pins that can get lost or stuck. Pull the handle and move the weight to quickly select the desired load.



The seat is made of blowmolded PE and mounted directly onto the steel frame, making it highly durable and resistant to wear and tear. To ensure comfort and a great user experience, the seat features an ergonomic groove. A seat height of 43 cm ensures easy access and transfer for wheelchair users.

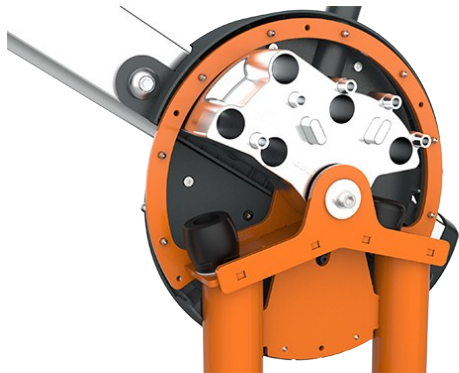

The machine features low operating noise thanks to an internal end stop made from TPE (thermoplastic elastomer). The damper absorbs impact energy from the weight with minimal rebound, reducing noise and vibration and ensuring a quieter, more controlled training experience.



Handles
The ergonomically shaped handles feature multiple grip areas to support adaptable training. This allows users between 140–205 cm in height to perform exercises with correct ergonomics while enabling a wide variety of exercises that target different muscle groups. The handles are made from cast aluminium with a grip texture finish.



The unilateral movement design ensures that each arm works independently, preventing compensation by the stronger side. The independent movement also allows for greater flexibility, enabling multiple exercise variations and supporting inclusive training for users of different abilities.

품번 FSW40300-0001

설치 정보

최대 낙하 높이	43 cm
안전 바닥 면적	17.2 m ²
총 설치 시간	5.9 시간
굴착량	0.00 m ³
콘크리트 사용량	0.00 m ³
기초 깊이 (표준)	0 cm
운송 중량	308 kg
고정 방식 옵션	

보증 정보

아연도금 / 도장 금속	10 년
알루미늄	15 년
이동 부품	2 년
중공 PE 부품	10 년
보증 대상 예비 부품	10 년

EN
16630
compliant

지속 가능성 데이터

FSW40300



Independent review certificate

Kompan A/S
C. F. Tietgens Blvd. 32C, 5220 Odense SØ

Bureau Veritas hereby attests that the CO₂e-calculations (covering materials, processing, waste and transport) done by Kompan for "Fitness", meet the requirements set by the listed standard.

Kompan A/S uses a selection of EPDs and emission factors from the Life Cycle Assessment database Ecoinvent 3.11. These values are reported as kg CO₂e, with all other impact categories excluded in line with the scope of ISO 14067:2018. The emission factors cover, material use, manufacturing processes, transport to Kompan, and electricity used during manufacturing. The presented emissions fall under GHG Protocol scope 3 emissions. Scope 1 and 2 are not presented. Scope 3 emissions include emission sources in the upstream value chain of a company, downstream emissions are excluded in this analysis.

Method: ISO 14067:2018 using GHG protocol guidance documents, reported as kg CO₂e.

Object

The verification has been done on the one pager "FAZ10100-0900" version: 27-10-2025. The supporting documentation "KOMPAN data_updated emissions factors_2025_V2" and "Emissions factors, EPD's and ecoinvent 3.11_2025" was also reviewed and approved.

Declaration

The review has been completed as a critical review with a limited assurance. I hereby confirm that nothing has come to the reviewer's attention which would lead to conclude that the study does not give an accurate depiction or isn't completed following method of the CO₂e calculation, the requirements of ISO 14067:2018, and 14071:2024, in the above referenced documentation.

Note: This verification only covers calculation elements according to method described in ISO 14067:2018 and may not be seen as a Life Cycle Assessment according to ISO 14067:2018.

Ref.: Kompan_Verification report 2025, 28-10-2025

Date of certificate: 29-10-2025

Expire date: 29-10-2027

Verified by: Julie Marie Vejsgaard Larsen, Environmental Auditor

Signature:

원료 채취 ~ 공장 출하 (A1~A3)	총 CO ₂ 배출량	CO ₂ 배출량 /kg	재활용 소재
	kg CO ₂ e	kg CO ₂ e/kg	%
FSW40300-0001	1,388.88	6.49	44.59

이 요소들에 적용된 전체 프레임워크는 환경 제품 선언 (Environmental Product Declaration, EPD) 으로, "제품의 전 과정에서 발생하는 환경 정보를 수치화하고, 동일한 기능을 수행하는 제품 간 비교를 가능하게 하는 것" (ISO, 2006) 을 목표로 합니다. 이 프레임워크는 구조를 준수하며, 원재료 단계부터 제조 단계 (A1-A3) 까지의 전체 제품 단계를 대상으로 한 전과정평가 (Life-Cycle Assessment, LCA) 접근법을 적용합니다.

Shoulder Press

FSW40300

KOMPANI®

* 최대 낙하 높이 | ** 전체 높이 | *** 안전 바닥 면적

* 최대 낙하 높이 | ** 전체 높이

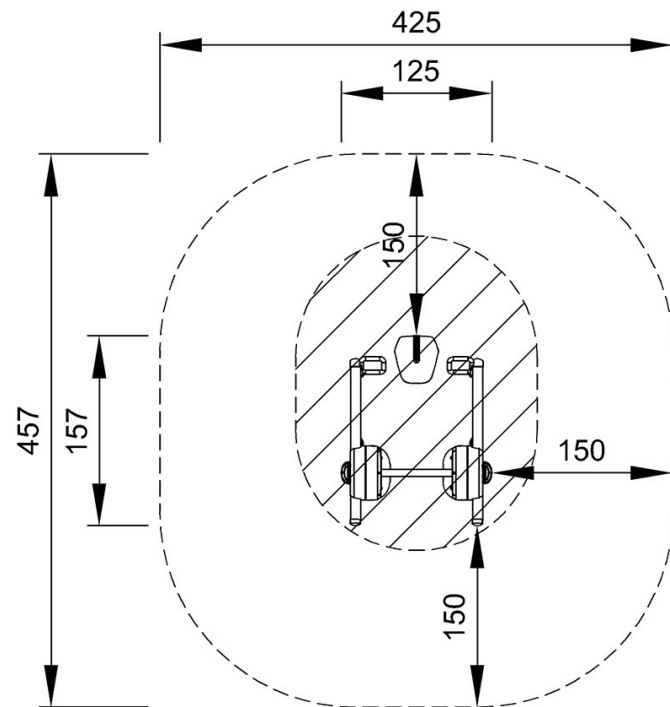

FSW40300
*43cm
**123cm
***17.2m²

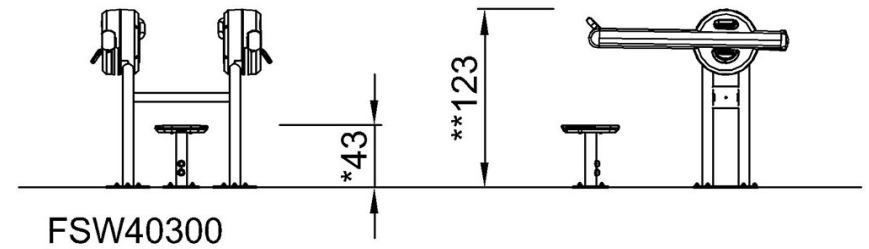

[위에서 보기](#)

[옆에서 보기](#)