

Baby Seat Swing

NRO902

KOMPANI
Let's play



Item no. NRO902-1001	
General Product Information	
Dimensions LxWxH	175x30x190 cm
Age group	1+
Play capacity (users)	1
Colour options	



The sturdy baby seat of the Baby Seat Swing is an irresistible invitation for infants and their care givers. The swinging motion of the Baby Seat Swing will make infants want to swing again and again. There are several benefits of this: firstly, the swing seat supports the seated infant all around so that the feeling of security is guaranteed. Secondly, the rubber seat is

placed in a good height for the infant to be in eye level with other children. The swinging motion trains the child's motor skills, specifically the sense of balance and space. Seated while swinging also trains the core muscles, all of these physical skills are fundamental to the infants ability to walk and navigate the surroundings securely. The action

also stimulates the understanding of cause and effect and thinking skills. Socially, swinging and getting pushed in the swing seat by parents, care givers or siblings is great fun.



Baby Seat Swing

NRO902



Toddler swing seat

Physical: balance, coordination and spatial awareness are developed when swinging.

These are necessary skills for judging distances and navigating. **Social-Emotional:** feeling of security from support. **Cognitive:** understanding of cause and effect.



Baby Seat Swing

NRO902



All Organic Robinia products by KOMPAN are made of Robinia wood from sustainable European sources. On request it can be supplied as FSC® Certified (FSC® C004450).



The baby seat is a two component seat with a PP inner core and outside rubber, produced in one operation. The seat is available with swing chains of either hot dip galvanised steel or stainless steel.



Swing suspensions are made of polyamide and consist of double ball bearing system with swivel.

Item no. NRO902-1001	
Installation Information	
Max. fall height	100 cm
Safety surfacing area	11.4 m ²
Total installation time	2.4
Excavation volume	0.14 m ³
Concrete volume	0.05 m ³
Footing depth (standard)	100 cm
Shipment weight	123 kg
Anchoring options	In-ground ✓
Warranty Information	
PUR components	10 years
Robinia wood	15 years
Spare parts guaranteed	10 years
Stainless steel components	Lifetime



The Robinia wood can be supplied as untreated raw wood or painted with a brown coloured transparent pigment that maintains the golden wood colour of the wood.



Sustainability Data

NRO902



Cradle to Gate A1-A3	Total CO ₂ emission	CO ₂ e/kg	Recycled materials
	kg CO ₂ e	kg CO ₂ e/kg	%
NRO902-1001	41.00	0.42	2.28

The overall framework applied for these factors is the Environmental Product Declaration (EPD), which quantifies "environmental information on the life cycle of a product and enable comparisons between products fulfilling the same function" (ISO, 2006). This follows the structure and applies a Life-Cycle Assessment approach to the entire Product stage from raw material through manufacturing (A1-A3))

Kompan A/S
 C.F. Tietgens Boulevard 32C
 DK-5220 Odense SØ
 Denmark



Verification of CO₂ calculation of: Nature play



Data version no. 2023-10-05

The CO₂ calculation and data are in compliance with the principles of a carbon footprint impact according to the GHG protocol (Greenhouse Gas Protocol), Scope 3, cradle to gate related to all individual components in the product category: "Nature play" represented by item no.: NRO409-0621.

(Scope 3 emissions include emission sources in the upstream and downstream value chain).

Date: 30. October 2023 | Valid until: 30. October 2025

Verified by:

Julie Marie Vejsgaard Larsen, LCA & EPD Consultant

Verification based on report: Validation of CO₂ calculation of 9 categories of Kompan product line, version 1.0, prepared by: Bureau Veritas HSE, Denmark: Julie M. V. Larsen.

Publication date: 30. October 2023

By Bureau Veritas HSE
 www.bureauveritas.dk
 +45 7731 1000



Baby Seat Swing

NRO902

* Max fall height | ** Total height | *** Safety surfacing area

* Max fall height | ** Total height

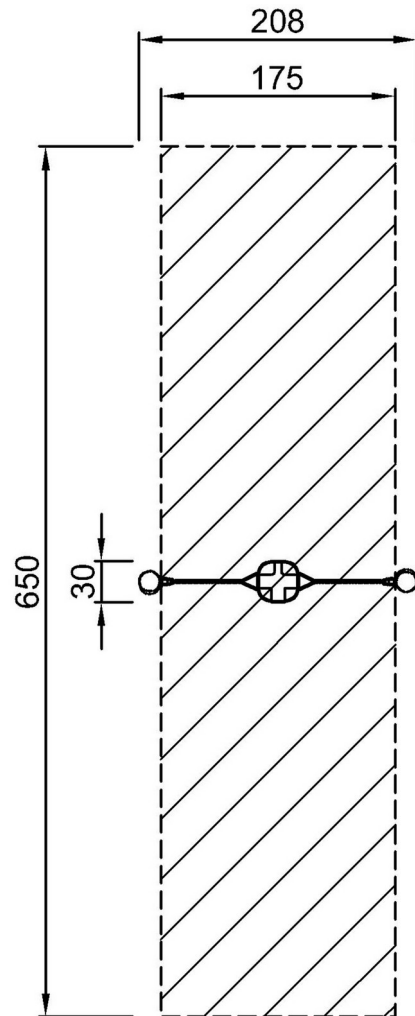

NRO902-1001
*100cm
**190cm
***11.4m²

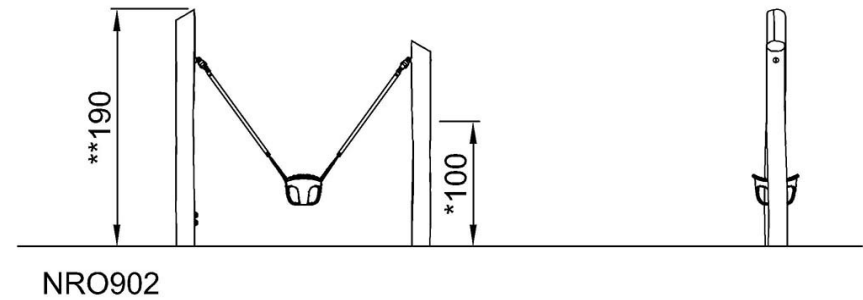

NRO902

[Click to see TOP VIEW](#)

[Click to see SIDE VIEW](#)